



High Voltage Instruments Ltd

LLT

High Voltage Instruments Ltd

1 Wellfield Court

Ibrox Business Park

Glasgow

G51 2JR

UK

Tel: +44(0)141 440 5800

Fax: +44(0)141 404 2561

Email: support@hvil.co.uk

Web: www.hvil.co.uk

CMR0059

ISSUE 8 01/09

LIVE LINE TESTER

INSTRUCTION MANUAL

TABLE OF CONTENTS

	PAGE
1. SAFETY RULES	2
2. DESCRIPTION	3
3. INSTRUCTIONS FOR USE	4
4. SPECIFICATIONS	
4.1 Electrical	11
4.2 Mechanical	11-12
4.3 Environmental	12
5. CARE AND MAINTENANCE	13
6. SPARES AND ACCESSORIES	13
7. LIMITED WARRANTY	14

1 SAFETY RULES



- 1.1 Only personnel who are fully trained in the use of Live Line Testers should use this equipment. The systems that it will be used on are powered from high voltages which can be lethal.
- 1.2 Before use ensure that the Tester and the accessories that are required for use are clean, free from cracks or deep scores, and are properly secured together.
- 1.3 Make certain that the Tester is properly rated for the voltage of the system under test.
- 1.4 Test the operation of the assembled Tester complete with accessories before and after each test (refer to Section 3).
- 1.5 Do not allow a live high voltage conductor to come in contact with the detector at point below the limit mark.
- 1.6 The Tester must never be used without a handle or without insulating rods incorporating a handle.
- 1.7 Safe working distances must always be observed.
- 1.8 Always connect the earth lead clip to a secure earthing point before performing a test. If the earth clip becomes disconnected during a test never handle the earth lip until the tester is removed from the line under test.

REMEMBER

SAFETY IS NO ACCIDENT!

**THIS TESTER SHOULD ONLY BE USED BY A COMPETENT,
SUITABLY TRAINED PERSON.**

7 LIMITED WARRANTY

High Voltage Instruments Ltd warrant instruments and test equipment manufactured by them to be free from defective material or factory workmanship and agree to repair or replace such products which, under normal use and service, disclose the defect to be the fault of our manufacturing, with no charge for parts and service. If we are unable to repair or replace the product, we will make a refund of the purchase price. Consult the Instruction Manual for instructions regarding the proper use and servicing of instruments and test equipment. Our obligation under this warranty is limited to repairing, replacing or making refund of any instrument or test equipment which proves to be defective within twelve months from the date of original purchase.

This warranty does not apply to any of our products which have been repaired or altered by unauthorised persons in any way so as, in our sole judgement, to injure their stability or reliability, or which have been subject to misuse, abuse, misapplication, negligence or accident or which have had the serial numbers altered, defaced or removed. Accessories, not of our manufacture used with this product, are not covered by this warranty.

To register a claim under the provisions of this warranty, return the instrument or test equipment to High Voltage Instruments Ltd, 1 Wellfield Court, Ibrox Business Park, Glasgow, G51 2JR, U.K. Upon our receipt and inspection of the product we will advise you as to the disposition of your claim.

ALL WARRANTIES IMPLIED BY LAW ARE HEREBY LIMITED TO A PERIOD OF TWELVE MONTHS, AND THE PROVISIONS OF THE WARRANTY ARE EXPRESSLY IN LIEU OF ANY OTHER WARRANTIES EXPRESSED OR IMPLIED.

The purchaser agrees to assume all liability for any damages and bodily injury which may result from the use or misuse of the product by the purchaser, his employees, or others, and the remedies provided for in this warranty are expressly in lieu of any other liability High Voltage Instruments Ltd may have including incidental or consequential damages.

High Voltage Instruments Ltd reserve the right to discontinue models at any time, or change specification, price or design, without notice and without incurring any obligation.

2 DESCRIPTION

2.1 GENERAL

The HVIL range of Live Line Testers has been designed for use on overhead lines and on switchgear. Models are available to cover system voltages from 3.3kV to 33kV 50/60Hz and can be used indoors and outdoors in all weathers.

Testers are used to measure the voltage between a line or conductor and earth or to check the phase relationship between two voltages.

2.2 PRINCIPLE OF OPERATION

A Live Line Tester is a device that draws current from the source under test. This current flows through a resistive chain to earth via an earth lead. The current flow is monitored and displayed on a moving coil meter which is graduated in kV.

When checking phase relationships a Phasing Rod is used in conjunction with a Live Line Tester. Currents from two sources are combined and displayed on the meter on the Tester. In-phase voltages will read twice the phase to earth voltage and out-of-phase voltages will read the phase to earth voltage only.

2.3 PROVING







Before and after using a Live Line Tester and associated accessories a functional test should be performed on the assembled items. A proving unit is provided for this purpose.

2.4 LIMIT MARK

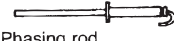
Near the contact end of the Tester and Phasing Rods there is a red band which is the limit mark. By definition this mark indicates the physical limit to which these items may be inserted between live components or may touch them.

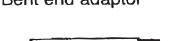
3 INSTRUCTIONS FOR USE

3.1 LIST OF EQUIPMENT

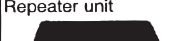
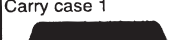
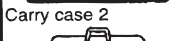
LIST OF EQUIPMENT					
PRODUCT	PART NO.				
	up to 3.3kV	up to 6.6kV	up to 11kV	up to 13.8kV	up to 33kV
 Tester c/w earth cord	F0262B	F0264B	F0256B	F0260B	F0257B
 Phasing rod c/w phasing lead	F0263B	F0265B	F0258B	F0261B	F0259B
 Bent end adaptor	DFH5028	DFH5028	DFH5028	DFH5028	DFH5028
 Extension rod	DFH5002	DFH5002	DFH5002	DFH5002	DFH5026
 Bowthorpe rod adaptor c/w lead	DFK0112	DFK0112	DFK0112	DFK0112	DFK0112
 Overhead line adaptor	DFK5000	DFK5000	DFK5000	DFK5000	DFK5000
 Proving unit c/w leads	FOP01B	FOP01B	FOP01B	FOP01B	FOP01B
 Repeater unit	FOR05B	FOR04B	FOR01B	FOR03B	FOR02B
 Carry case 1	CMP5009	CMP5009	CMP5009	CMP5009	
 Carry case 2	CMP5008	CMP5008	CMP5008	CMP5008	CMP5008
 Carry bag	CMP5010	CMP5010	CMP5010	CMP5010	CMP5023

5 CARE AND MAINTENANCE

5.1 STORAGE

The Tester and its accessories should be stored in the proprietary carrying case/bag when not in use.

5.2 TRANSPORTING

When the equipment is in transit it should be stored in its carrying case/bag. Whilst the equipment has been designed for field use it should not be subjected to excessive bumps and shocks.

5.3 CLEANLINESS

Dirt can cause surface tracking and it is therefore necessary to keep the Tester and its accessories clean by washing with detergent solution. The Tester and other parts constructed from fibreglass and PVC should then be polished with the liquid polymer polish provided.

5.4 MECHANICAL DAMAGE

If surface scratches or dents can easily be seen by the naked eye, then the equipment should be returned to the manufacturer for repair since these blemishes act as traps for dirt and moisture. Mechanical damage to screw threads would also necessitate the return of the equipment to the manufacturer.

5.5 RECALIBRATION AND PROOF TESTING

Every twelve months the Tester and its accessories should be rechecked. This should include pressure testing, radial voltage proof testing, torque testing of bushes and accuracy of indication. It is recommended that this be carried out by the manufacturer.

6 SPARES AND ACCESSORIES

6.1	Earth Lead	DFH5044
6.2	Proving/Phasing Lead	DFH5045
6.3	Hot Connector (Tester or Phasing Rod)	DDH5001
6.4	Hot Connector (Extension Rod)	DDH5000
6.5	Bent End Adaptor	DFH5028
6.6	Cleaning Kit	DDM5003
6.7	Battery 8 X 1.5V Type IEC R20	CEJ0000
6.8	Instruction Manual	CMR0059

Material: PVC. Moulded polycarbonate. Resin bonded fibreglass, Aluminium/stainless steel

EXTENSION ROD

SYSTEM VOLTAGE 3.3kV to 13.8kV 33kV
 Length: 907mm 907mm
 Weight: 650gm 700gm
 Material: PVC. Resin bonded fibreglass, Aluminium/stainless steel

BOWTHORPE ROD ADAPTOR

Length: 360mm
 Weight: 1350gm
 Material: Resin bonded fibreglass Aluminium/stainless steel

BENT END ADAPTOR (STANDARD)

Length (developed): 675mm
 Weight: 270gm
 Material: Moulded polypropylene Stainless steel

OVERHEAD LINE ADAPTOR

Height: 90mm
 Weight: 100gm
 Material: Aluminium/stainless steel

REPEATER AND PROVING UNITS

Case Dimensions: 185 X 145 X 120mm
 Case Material: Moulded ABS
 Vibration Resistance: To IEC 68-2-6
 Drop Resistance: To IEC 68-2-32
 Shock Resistance: To IEC 529

4.3 ENVIRONMENTAL

Operating Temperature: -25° C to +50° C
 Water Ingress: To IEC 529
 'wet' testing according to IEC Technical Committee No 78, i.e. all items except the proving unit may be used outdoors in all weathers
 Cold Temperature: To IEC 68-2-1
 Dry Heat: To IEC 68-2-2
 Damp Heat: To IEC 68-2-3

3.2 ASSEMBLING THE EQUIPMENT

3.2.1 For Use on Overhead Lines from Poles or Towers

3.2 ASSEMBLING THE EQUIPMENT

3.2.1 For Use on Overhead Lines from Poles or Towers

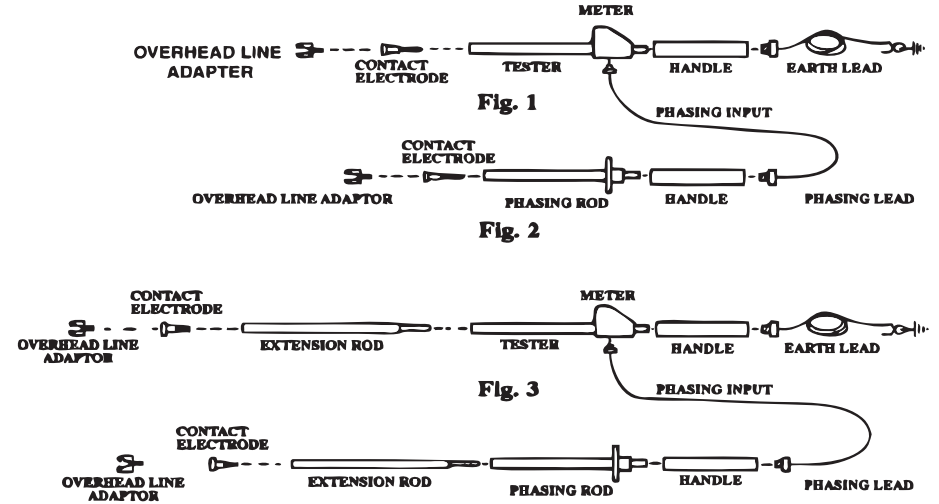

When voltage tests are to be carried out on overhead lines from poles or towers, the Tester should be assembled as shown in Fig. 1. If a longer reach is required then an Extension Rod can be added as in Fig. 3.

If it is required to check the phase relationship between the voltages on two conductors then the Phasing Rod should be assembled as shown in Figs. 2 and 4 and linked to the Tester phasing inputs in Figs. 1 and 3 respectively.

3.2.2 For Use on Overhead Lines from Ground Level

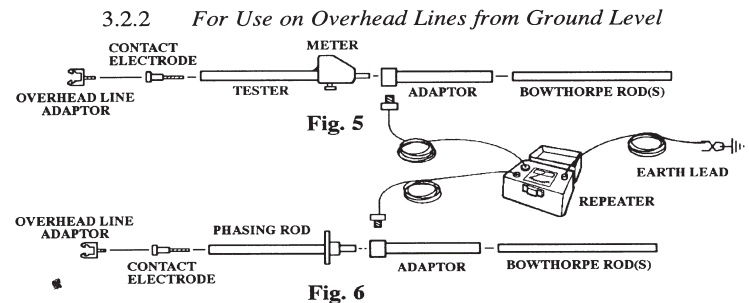

When performing voltage tests from ground level the Tester is assembled as shown in Fig. 5 with sufficient Bowthorpe rods to give the necessary reach. The Repeater is placed on the ground and the readings displayed are the same as those on the Tester.

To carry out phasing tests the Phasing Rod is assembled as shown in Fig. 6 and then coupled to the Repeater in Fig. 5 so that the resultant voltage is displayed.

The Tester in Fig. 5 can be replaced with a Phasing Rod since the meter on the Tester is often not visible and the readings are taken from the meter on the Repeater Unit.

3.2.3 For Use on Switchgear

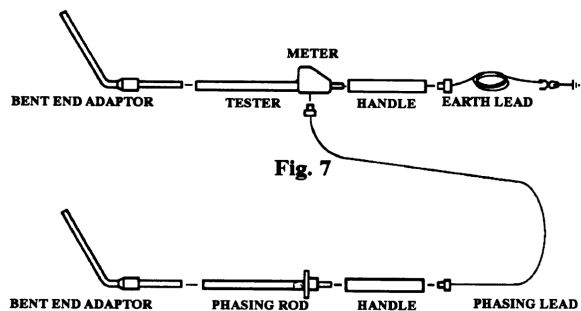

Fig. 8

To measure voltages on switchgear the Tester is assembled as shown in Fig. 7. The meter on the Tester can be rotated to the line up with the Bent End Adaptor for ease of reading.

When performing phasing tests the Phasing Rod is assembled as shown in Fig. 8 and linked to the Tester phasing input on the meter in Fig. 7.

3.3 USING THE EQUIPMENT

3.3.1 Assemble the equipment as required; refer to section 3.2.

3.3.2 The completely assembled equipment must be proved before and after use. A Proving Unit is provided which generates a nominal 4kV for checking the full scale deflection of the meter on the Tester and the Repeater Unit.

3.3.3 Proving A Tester

4 SPECIFICATIONS

4.1 ELECTRICAL

TESTER

SYSTEM VOLTAGE	3.3kV	6.6kV	11kV	13.8kV	33kV
Resistor Chain Value ($\pm 5\%$):	22.5M Ω	52.5M Ω	75M Ω	100M Ω	225M Ω
Measuring Range:	5kV	10kV	15kV	20kV	40kV
Accuracy:	$\pm 5\%$ of FSD				
Movement:	100 μ A taut band suspension				

PHASING ROD

Resistor Chain Value:	As for Tester
-----------------------	---------------

REPEATER UNIT

Measuring Range:	As for Tester
Accuracy:	As for Tester
Movement:	As for Tester

PROVING UNIT

Battery:	8 X 1.5V IEC R20 or equivalent
Battery Consumption:	<200mA on high voltage generation with 12V supply
High Voltage Output:	3 to 5kV D.C. at 100 μ A max. current
Low Voltage A.C. source:	Variable 0 to 200 μ A at 50Hz nominal with a short circuit current of <1mA

SAFETY

EMC:	To BS EN 50081-1 BS EN 50082-1
------	-----------------------------------

4.2 MECHANICAL

TESTER

SYSTEM VOLTAGE	3.3kV to 13.8kV	33kV
Length:	1025mm	1200mm
Weight:	2000gm	2300gm
Material:	PVC. Moulded polycarbonate. Resin bonded fibreglass, Aluminium/stainless steel	
Meter Housing Adjustment:	340° stop to stop	

PHASING ROD

SYSTEM VOLTAGE	3.3kV to 13.8kV	33kV
Length:	1025mm	1200mm
Weight:	1400gm	1600gm

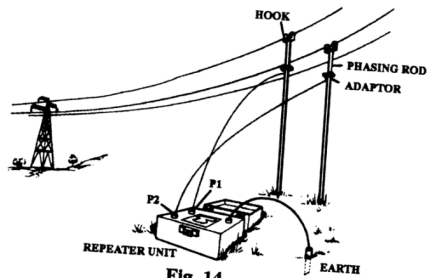

Fig. 14

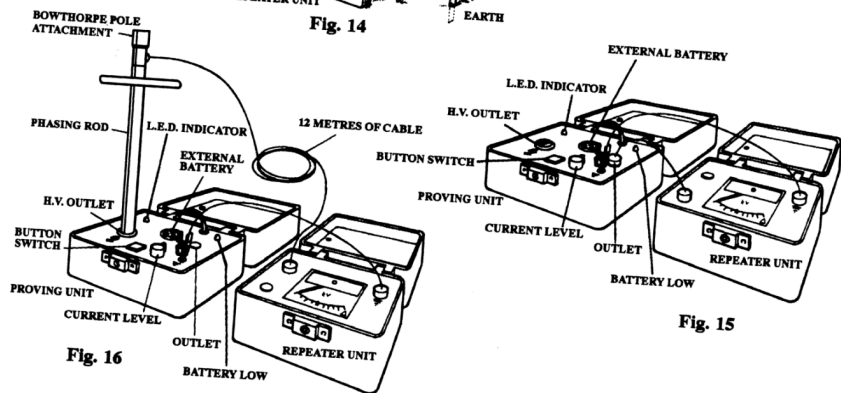

Fig. 16

Using the set-up shown in Fig. 15 check the full scale deflection of the meter on the Repeater Unit by depressing the Proving Unit operating button and rotating the current level control.

Fig. 16 shows the set-up for proving a Phasing Rod with a Bowthorpe Adaptor, in place of a handle, in conjunction with a Repeater Unit. Each Phasing Rod is proved in turn by inserting its contact end into the HV outlet and observing that the meter on the Repeater Unit indicates between 3 and 5kV.

Using one Phasing Rod assembly, check each line voltage and note the readings. Then, using both Phasing Rods, the resultant voltages to earth are measured and compared with the line voltages to ascertain the phase relationship.

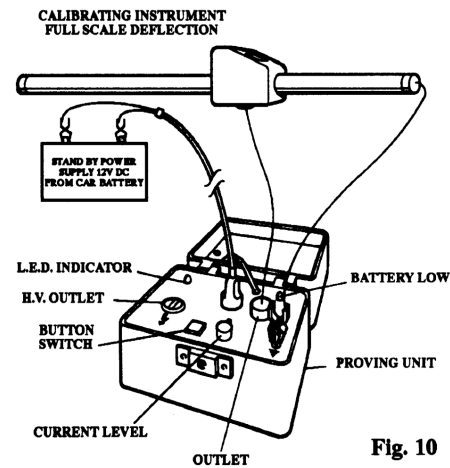

Fig. 10

To check the high resistance chain connect the Tester to the Proving Unit and insert the contact electrode into the high voltage outlet as in Fig. 9. Observe good battery condition (low battery in the proving unit is indicated by a flashing light). Check that the meter on the Tester reads between 3 and 5kV.

NOTE: In the event of low battery indication, remove battery cover lid of proving unit and replace batteries. If replacement batteries are not readily available, the proving unit can be powered from a standard 12V vehicle battery using the lead provided as shown in Fig. 10.

To check for full scale deflection of the meter, connect the Tester to the Proving Unit as shown in Fig. 10.

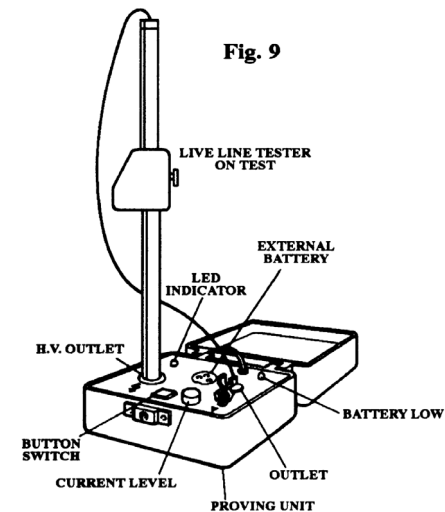
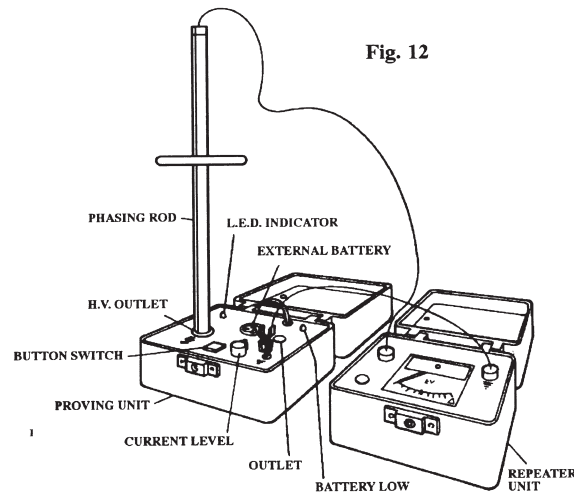
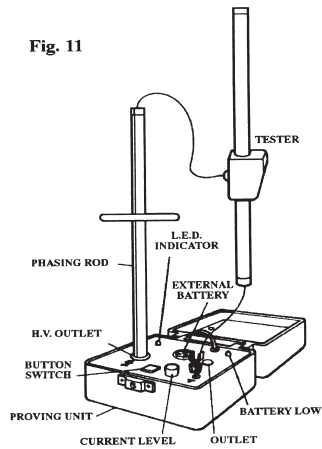

Fig. 9

3.3.4 Proving a Phasing Rod

A Phasing Rod may be proved using a Proving Unit in conjunction with a Tester or a Repeater Unit, refer to Figs. 11 and 12.



In each case the Phasing Rod contact electrode is inserted into the high voltage outlet on the proving unit and the meter on the Tester or Repeater Unit should read between 3 and 5kV.

3.3.5 Proving an Extension Rod/Bent End Adaptor Fit an Extension Rod or Bent End Adaptor to a Tester and perform the test detailed in 3.3.3.

3.3.6 Measuring Voltages

With the equipment assembled as in figures 1,3 or 5 as necessary firstly connect the earth lead clip to a secure earthing point. Now touch the Tester onto the line under test and the voltage will be displayed on the meter.

Note: The voltage will also be displayed on the repeater if incorporated.

3.3.7 Checking phase Relationships

To check phase relationships the equipment should be assembled as in figures 1/2, 3/4, 5/6 and 7/8 as necessary. Each phase to earth voltage should firstly be measured and then the combined / resultant voltages are measured and compared with the values for the individual phases.

If the voltage on the two phases are in-phase then the resultant voltage to earth is twice the phase voltage. If the voltages are out-of-phase then the resultant voltage to earth is the same as the phase voltage.

PHASE	SYSTEM VOLTAGE kV					
	3.3	6.6	11	13.8	33	
A1	1.9	3.8	6.35	8	19	PHASE VOLTAGE TO EARTH kV
B1	1.9	3.8	6.35	8	19	
C1	1.9	3.8	6.35	8	19	
A2	1.9	3.8	6.35	8	19	
B2	1.9	3.8	6.35	8	19	
C2	1.9	3.8	6.35	8	19	
A1 + A2	3.8 in-phase	7.6 in-phase	12.7 in-phase	16 in-phase	38 in-phase	RESUL- TANT VOLTAGE TO EARTH kV
A1 + B2	1.9) out	3.8) out	6.35) out	8) out	1.9) out	
A1 + C2	1.9) of	3.8) of	6.35) of	8) out	1.9) of	
A1 + A2	1.9) phase	3.8) phase	6.35) phase	8) out	1.9) phase	
B1 + B2	3.8 in-phase	7.6 in-phase	12.7 in-phase	16 in-phase	38 in-phase	
B1 + C2	1.9) out	3.8) out	6.35) out	8) out	1.9) out	
C1 + A2	1.9) of	3.8) of	6.35) of	8) out	1.9) of	
C1 + B2	1.9) phase	3.8) phase	6.35) phase	8) out	1.9) phase	
C1 + C2	3.8 in-phase	7.6 in-phase	12.7 in-phase	16 in-phase	38 in-phase	

Table 1

If it is required to check phase relationships on overhead lines then the set-up as shown in Fig. 14 can be used with Bowthorpe Rod Adaptors and Rods fitted to Phasing Rods carrying Overhead Line Hooks.

NOTE: Either or both Phasing Rods can be replaced by a Tester.