



SMART^{EC}
Eurotest Combo
MI 3125
Instruction manual
Version 1.2, Code no 20 751 483

Distributor:

Manufacturer:

METREL d.d.
Ljubljanska cesta 77
1354 Horjul
Slovenia
web site: <http://www.metrel.si>
e-mail: metrel@metrel.si



Mark on your equipment certifies that this equipment meets the requirements of the EU (European Union) concerning safety and electromagnetic compatibility regulations

© 2010 METREL

The trade names Metrel, Smartec, Eurotest, Autosequence are trademarks registered or pending in Europe and other countries.

No part of this publication may be reproduced or utilized in any form or by any means without permission in writing from METREL.

Table of contents

1	Preface	5
2	Safety and operational considerations.....	6
2.1	Warnings and notes	6
2.2	Battery and charging	9
2.2.1	<i>New battery cells or cells unused for a longer period</i>	<i>10</i>
2.3	Standards applied	10
3	Instrument description.....	12
3.1	Front panel	12
3.2	Connector panel	13
3.3	Back side.....	14
3.4	Display organization	15
3.4.1	<i>Terminal voltage monitor.....</i>	<i>15</i>
3.4.2	<i>Battery indication.....</i>	<i>15</i>
3.4.3	<i>Message field.....</i>	<i>15</i>
3.4.4	<i>Result field</i>	<i>16</i>
3.4.5	<i>Sound warnings</i>	<i>16</i>
3.4.6	<i>Help screens</i>	<i>16</i>
3.4.7	<i>Backlight and contrast adjustments</i>	<i>17</i>
4	Instrument operation.....	18
4.1	Function selection	18
4.2	Settings	19
4.2.1	<i>Language</i>	<i>19</i>
4.2.2	<i>Initial settings</i>	<i>20</i>
4.2.3	<i>RCD standard</i>	<i>21</i>
4.2.4	<i>Z factor.....</i>	<i>22</i>
4.2.5	<i>Commander support</i>	<i>22</i>
5	Measurements	24
5.1	Voltage, frequency and phase sequence	24
5.2	Insulation resistance.....	26
5.3	Continuity	28
5.3.1	<i>Compensation of test leads resistance</i>	<i>30</i>
5.4	Testing RCDs	31
5.4.1	<i>Contact voltage (RCD Uc).....</i>	<i>32</i>
5.4.2	<i>Trip-out time (RCDt).....</i>	<i>33</i>
5.4.3	<i>Trip-out current (RCD I)</i>	<i>34</i>
5.4.4	<i>RCD Autotest</i>	<i>34</i>
5.5	Fault loop impedance and prospective fault current	37
5.6	Line impedance and prospective short-circuit current	39
5.6.1	<i>Line impedance and prospective short circuit current.....</i>	<i>40</i>
5.6.2	<i>Voltage drop.....</i>	<i>41</i>
5.7	PE test terminal	43
6	Maintenance.....	45
6.1	Fuse replacement.....	45
6.2	Cleaning	45

6.3	Periodic calibration	45
6.4	Upgrading the instrument	45
6.5	Service	46
7	Technical specifications	47
7.1	Insulation resistance	47
7.2	Continuity	47
7.3	RCD testing	48
7.3.1	<i>General data</i>	48
7.3.2	<i>Contact voltage RCD-Uc</i>	48
7.3.3	<i>Trip-out time</i>	48
7.3.4	<i>Trip-out current</i>	49
7.4	Fault loop impedance and prospective fault current	49
7.4.1	<i>No disconnecting device or FUSE selected</i>	49
7.4.2	<i>RCD selected</i>	50
7.5	Line impedance and prospective short-circuit current / Voltage drop	50
7.6	Voltage, frequency, and phase rotation	51
7.6.1	<i>Phase rotation</i>	51
7.6.2	<i>Voltage</i>	51
7.6.3	<i>Frequency</i>	51
7.6.4	<i>Online terminal voltage monitor</i>	51
7.7	General data	51
A	Appendix A - Fuse table	53
A.1	Fuse table - impedances (UK)	53
B	Appendix B - Accessories for specific measurements	54

1 Preface

Congratulations on your purchase of the Eurotest instrument and its accessories from METREL. The instrument was designed on a basis of rich experience, acquired through many years of dealing with electric installation test equipment.

The Eurotest instrument is professional, multifunctional, hand-held test instrument intended to perform all the measurements required in order for a total inspection of electrical installations in buildings. The following measurements and tests can be performed:

- Voltage and frequency,
- Continuity tests,
- Insulation resistance tests,
- RCD testing,
- Fault loop / RCD trip-lock impedance measurements,
- Line impedance / Voltage drop,
- Phase sequence,

The graphic display with backlight offers easy reading of results, indications, measurement parameters and messages. Two LED Pass/Fail indicators are placed at the sides of the LCD.

The operation of the instrument is designed to be as simple and clear as possible and no special training (except for the reading this instruction manual) is required in order to begin using the instrument.

In order for operator to be familiar enough with performing measurements in general and their typical applications it is advisable to read Metrel handbook *Guide for testing and verification of low voltage installations*.

The instrument is equipped with the entire necessary accessory for comfortable testing.

2 Safety and operational considerations

2.1 Warnings and notes

In order to maintain the highest level of operator safety while carrying out various tests and measurements Metrel recommends keeping your Eurotest instruments in good condition and undamaged. When using the instrument, consider the following general warnings:

- ❑ The  symbol on the instrument means »Read the Instruction manual with special care for safe operation«. The symbol requires an action!
- ❑ If the test equipment is used in a manner not specified in this user manual, the protection provided by the equipment could be impaired!
- ❑ Read this user manual carefully, otherwise the use of the instrument may be dangerous for the operator, the instrument or for the equipment under test!
- ❑ Do not use the instrument or any of the accessories if any damage is noticed!
- ❑ If a fuse blows in the instrument, follow the instructions in this manual in order to replace it!
- ❑ Consider all generally known precautions in order to avoid risk of electric shock while dealing with hazardous voltages!
- ❑ Do not use the instrument in supply systems with voltages higher than 550 V!
- ❑ Service intervention or adjustment is only allowed to be carried out by a competent authorized personnel!
- ❑ Use only standard or optional test accessories supplied by your distributor!
- ❑ Consider that older accessories and some of the new optional test accessories compatible with this instrument only meet CAT III / 300 V overvoltage safety rating! This means that maximal allowed voltage between test terminals and ground is 300 V!
- ❑ The instrument comes supplied with rechargeable Ni-Cd or Ni-MH battery cells. The cells should only be replaced with the same type as defined on the battery compartment label or as described in this manual. Do not use standard alkaline battery cells while the power supply adapter is connected, otherwise they may explode!
- ❑ Hazardous voltages exist inside the instrument. Disconnect all test leads, remove the power supply cable and switch off the instrument before opening the battery compartment.
- ❑ All normal safety precautions must be taken in order to avoid risk of electric shock while working on electrical installations!

Warnings related to measurement functions:

Insulation resistance

- Insulation resistance measurement should only be performed on de-energized objects!
- Do not touch the test object during the measurement or before it is fully discharged! Risk of electric shock!
- When an insulation resistance measurement has been performed on a capacitive object, automatic discharge may not be done immediately! The warning message  and the actual voltage is displayed during discharge until voltage drops below 10 V.
- Do not connect test terminals to external voltage higher than 600 V (AC or DC) in order not to damage the test instrument!

Continuity functions

- Continuity measurements should only be performed on de-energized objects!
- Parallel impedances or transient currents may influence test results.

Testing PE terminal

- If phase voltage is detected on the tested PE terminal, stop all measurements immediately and ensure the cause of the fault is eliminated before proceeding with any activity!

Notes related to measurement functions:

General

- The  indicator means that the selected measurement cannot be performed because of irregular conditions on input terminals.
- Insulation resistance and continuity functions can only be performed on de-energized objects.
- PASS / FAIL indication is enabled when limit is set. Apply appropriate limit value for evaluation of measurement results.
- In the case that only two of the three wires are connected to the electrical installation under test, only voltage indication between these two wires is valid.

Insulation resistance

- If voltages of higher than 10 V (AC or DC) is detected between test terminals, the insulation resistance measurement will not be performed. If voltages of higher than 10 V (AC or DC) is detected between test terminals, the insulation resistance measurement will not be performed.
- The instrument automatically discharge tested object after finished measurement.
- A double click of TEST key starts a continuous measurement.

Continuity functions

- If voltages of higher than 10 V (AC or DC) is detected between test terminals, the continuity resistance test will not be performed.
- Before performing a continuity measurement, where necessary, compensate test lead resistance.

RCD functions

- Parameters set in one function are also kept for other RCD functions!
- The measurement of contact voltage does not normally trip an RCD. However, the trip limit of the RCD may be exceeded as a result of leakage current flowing to the PE protective conductor or a capacitive connection between L and PE conductors.
- The RCD trip-lock sub-function (function selector switch in LOOP position) takes longer to complete but offers much better accuracy of fault loop resistance (in comparison to the R_L sub-result in Contact voltage function).
- RCD trip-out time and RCD trip-out current measurements will only be performed if the contact voltage in the pre-test at nominal differential current is lower than the set contact voltage limit!
- The autotest sequence (RCD AUTO function) stops when trip-out time is out of allowable time period.

Z-LOOP

- The low limit prospective short-circuit current value depends on fuse type, fuse current rating, fuse trip-out time and impedance scaling factor.
- The specified accuracy of tested parameters is valid only if the mains voltage is stable during the measurement.
- Fault loop impedance measurements will trip an RCD.
- The measurement of fault loop impedance using trip-lock function does not normally trip an RCD. However, the trip limit may be exceeded as a result of leakage current flowing to the PE protective conductor or a capacitive connection between L and PE conductors.

Z-LINE / VOLTAGE DROP

- In case of measurement of $Z_{\text{Line-Line}}$ with the instrument test leads PE and N connected together the instrument will display a warning of dangerous PE voltage. The measurement will be performed anyway.
- Specified accuracy of tested parameters is valid only if mains voltage is stable during the measurement.

2.2 Battery and charging

The instrument uses six AA size alkaline or rechargeable Ni-Cd or Ni-MH battery cells. Nominal operating time is declared for cells with nominal capacity of 2100 mAh.

Battery condition is always displayed in the lower right display part.

In case the battery is too weak the instrument indicates this as shown in figure 2.1. This indication appears for a few seconds and then the instrument turns itself off.

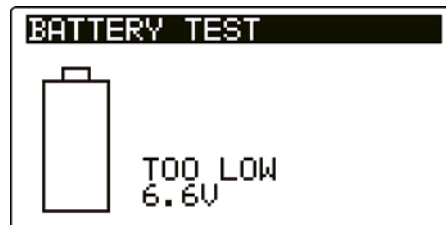

Figure 2.1: Discharged battery indication

The battery is charged whenever the power supply adapter is connected to the instrument. The power supply socket polarity is shown in figure 2.2. Internal circuit controls charging and assures maximum battery lifetime.



Figure 2.2: Power supply socket polarity

The instrument automatically recognizes the connected power supply adapter and begins charging.

Symbols:

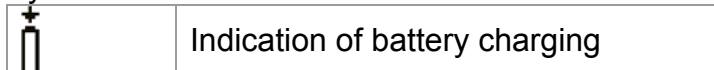

Figure 2.3: Charging indication

- ❑ When connected to an installation, the instruments battery compartment can contain hazardous voltage inside! When replacing battery cells or before opening the battery/fuse compartment cover, disconnect any measuring accessory connected to the instrument and turn off the instrument,
- ❑ Ensure that the battery cells are inserted correctly otherwise the instrument will not operate and the batteries could be discharged.
- ❑ If the instrument is not to be used for a long period of time, remove all batteries from the battery compartment.
- ❑ Alkaline or rechargeable Ni-Cd or Ni-MH batteries (size AA) can be used. Metrel recommends only using rechargeable batteries with a capacity of 2100mAh or above.
- ❑ Do not recharge alkaline battery cells!
- ❑ Use only power supply adapter delivered from the manufacturer or distributor of the test equipment to avoid possible fire or electric shock!

2.2.1 New battery cells or cells unused for a longer period

Unpredictable chemical processes can occur during the charging of new battery cells or cells that have been left unused for a longer period (more than 3 months). Ni-MH and Ni-Cd cells can be subjected to these chemical effects (sometimes called the memory effect). As a result the instrument operation time can be significantly reduced during the initial charging/discharging cycles of the batteries.

In this situation, Metrel recommend the following procedure to improve the battery lifetime:

Procedure	Notes
➤ Completely charge the battery.	At least 14h with in-built charger.
➤ Completely discharge the battery.	This can be performed by using the instrument normally until the instrument is fully discharged.
➤ Repeat the charge / discharge cycle at least 2-4 times.	Four cycles are recommended in order to restore the batteries to their normal capacity.

Notes:

- ❑ The charger in the instrument is a pack cell charger. This means that the battery cells are connected in series during the charging. The battery cells have to be equivalent (same charge condition, same type and age).
- ❑ One different battery cell can cause an improper charging and incorrect discharging during normal usage of the entire battery pack (it results in heating of the battery pack, significantly decreased operation time, reversed polarity of defective cell,...).
- ❑ If no improvement is achieved after several charge / discharge cycles, then each battery cell should be checked (by comparing battery voltages, testing them in a cell charger, etc). It is very likely that only some of the battery cells are deteriorated.
- ❑ The effects described above should not be confused with the normal decrease of battery capacity over time. Battery also loses some capacity when it is repeatedly charged / discharged. Actual decreasing of capacity, versus number of charging cycles, depends on battery type. This information is provided in the technical specification from battery manufacturer.

2.3 Standards applied

The Eurotest instruments are manufactured and tested in accordance with the following regulations:

Electromagnetic compatibility (EMC)

BS EN 61326 Electrical equipment for measurement, control and laboratory use – EMC requirements
 Class B (Hand-held equipment used in controlled EM environments)

Safety (LVD)

BS EN 61010-1	Safety requirements for electrical equipment for measurement, control and laboratory use – Part 1: General requirements
BS EN 61010-031	Safety requirements for hand-held probe assemblies for electrical measurement and test
BS EN 61010-2-032	Safety requirements for electrical equipment for measurement, control, and laboratory use - Part 2-032: Particular requirements for hand-held and hand-manipulated current sensors for electrical test and measurement

Functionality

BS EN 61557	Electrical safety in low voltage distribution systems up to 1000 V _{AC} and 1500 V _{AC} – Equipment for testing, measuring or monitoring of protective measures Part 1 General requirements Part 2 Insulation resistance Part 3 Loop resistance Part 4 Resistance of earth connection and equipotential bonding Part 6 Residual current devices (RCDs) in TT and TN systems Part 7 Phase sequence Part 10 Combined measuring equipment
-------------	---

Other reference standards for testing RCDs

BS EN 61008	Residual current operated circuit-breakers without integral overcurrent protection for household and similar uses
BS EN 61009	Residual current operated circuit-breakers with integral overcurrent protection for household and similar uses
EN 60364-4-41	Electrical installations of buildings Part 4-41 Protection for safety – protection against electric shock
EN 60364-5-52	Low-voltage electrical installations – Part 5-52: Selection and erection of electrical equipment – Wiring systems
BS 7671	IEE Wiring Regulations (17 th edition)
AS / NZ 3760	In-service safety inspection and testing of electrical equipment

Note about EN and IEC standards:

- Text of this manual contains references to European and British standards. All standards of EN 6XXXX (e.g. EN 61010) series are equivalent to IEC standards with the same number (e.g. IEC 61010) and differ only in amended parts required by European harmonization procedure.

3 Instrument description

3.1 Front panel



Figure 3.1: Front panel

Legend:

1	LCD	128 x 64 dots matrix display with backlight.
2	TEST	TEST Starts measurements. Acts also as the PE touching electrode.
3	UP	Modifies selected parameter.
4	DOWN	
5	CAL	Calibrates test leads in Continuity functions. Starts Z_{REF} measurement in Voltage drop sub-function.
6	Function selectors	Selects test function.
7	Backlight, Contrast	Changes backlight level and contrast.
8	ON / OFF	Switches the instrument power on or off. <i>The instrument automatically turns off 15 minutes after the last key was pressed.</i>
		In RCD Auto toggles between top and bottom parts of results field.
9	HELP	Accesses help menus.
10	TAB	Selects the parameters in selected function.
11	PASS	Indicates PASS/ FAIL of result.
12	FAIL	

3.2 Connector panel

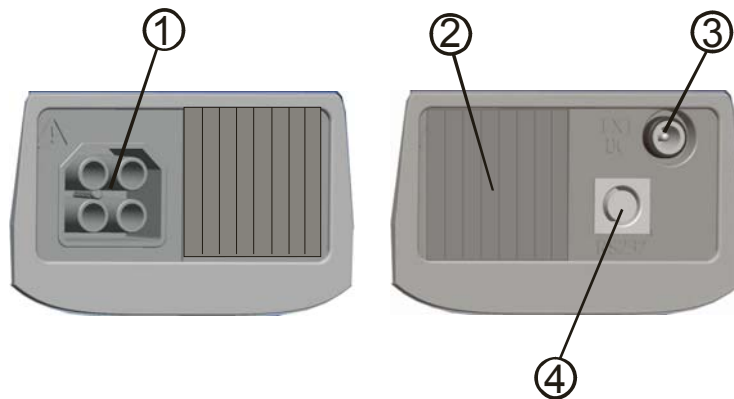

Figure 3.2: Connector panel

Legend:

1	Test connector	Measuring inputs / outputs
2	Protection cover	
3	Charger socket	
4	PS/2 connector	Serial port for upgrading the instrument.

Warnings!

- ❑ **Maximum allowed voltage between any test terminal and ground is 600 V!**
- ❑ **Maximum allowed voltage between test terminals is 600 V!**
- ❑ **Maximum short-term voltage of external power supply adapter is 14 V!**

3.3 Back side



Figure 3.3: Back side

Legend:

1	Side belt
2	Battery compartment cover
3	Fixing screw for battery compartment cover
4	Back panel information label
5	Holder for inclined position of the instrument
6	Magnet for fixing instrument close to tested item (optional)

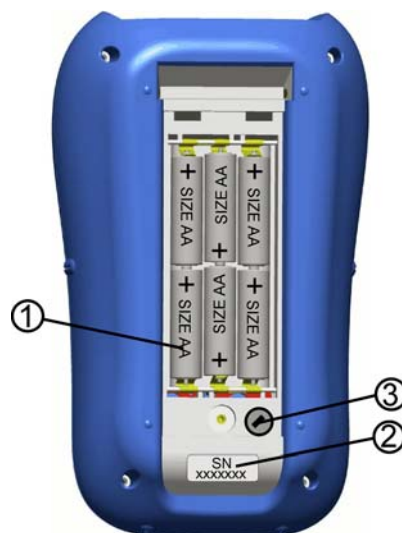

Figure 3.4: Battery compartment

Legend:

1	Battery cells	Size AA, alkaline or rechargeable NiMH / NiCd
2	Serial number label	
3	Fuse	M 0.315 A, 250 V

3.4 Display organization

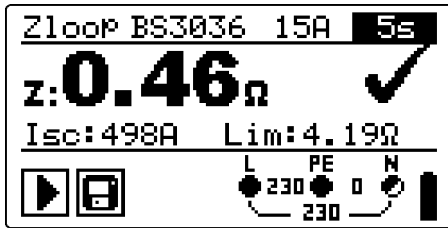

Figure 3.5: Typical function display

	Function name
z: 0.46 Ω ✓ Isc: 498A Lim: 4.19Ω	Result field
BS3036 15A 5s	Test parameter field
	Message field
	Terminal voltage monitor
	Battery indication

3.4.1 Terminal voltage monitor

The terminal voltage monitor displays on-line the voltages on the test terminals and information about active test terminals.

	Online voltages are displayed together with test terminal indication. All three test terminals are used for selected measurement.
	Online voltages are displayed together with test terminal indication. L and N test terminals are used for selected measurement.
	L and PE are active test terminals; N terminal should also be connected for correct input voltage condition.

3.4.2 Battery indication







The indication indicates the charge condition of battery and connection of external charger.

	Battery capacity indication.
	Low battery. Battery is too weak to guarantee correct result. Replace or recharge the battery cells.
	Recharging in progress (if power supply adapter is connected).



3.4.3 Message field

In the message field warnings and messages are displayed.

	Measurement is running, consider displayed warnings.
	Conditions on the input terminals allow starting the measurement; consider other displayed warnings and messages.
	Conditions on the input terminals do not allow starting the measurement, consider displayed warnings and messages.
	RCD tripped-out during the measurement (in RCD functions).

	Instrument is overheated. The measurement is prohibited until the temperature decreases under the allowed limit.
	High electrical noise was detected during measurement. Results may be impaired.
	L and N are changed.
	Warning! High voltage is applied to the test terminals.
	Warning! Dangerous voltage on the PE terminal! Stop the activity immediately and eliminate the fault / connection problem before proceeding with any activity!
	Test leads resistance in Continuity measurement is not compensated.
	Test leads resistance in Continuity measurement is compensated.

3.4.4 Result field

	Measurement result is inside pre-set limits (PASS).
	Measurement result is out of pre-set limits (FAIL).
	Measurement is aborted. Consider displayed warnings and messages.

3.4.5 Sound warnings

Continuous sound **Warning!** Dangerous voltage on the PE terminal is detected.

3.4.6 Help screens

HELP	Opens help screen.
-------------	--------------------

Help menus are available in all functions. The Help menu contains schematic diagrams for illustrating how to properly connect the instrument to electric installation. After selecting the measurement you want to perform, press the HELP key in order to view the associated Help menu.

Keys in help menu:

UP / DOWN	Selects next / previous help screen.
HELP	Scrolls through help screens.
Function selectors / TEST	Exits help menu.

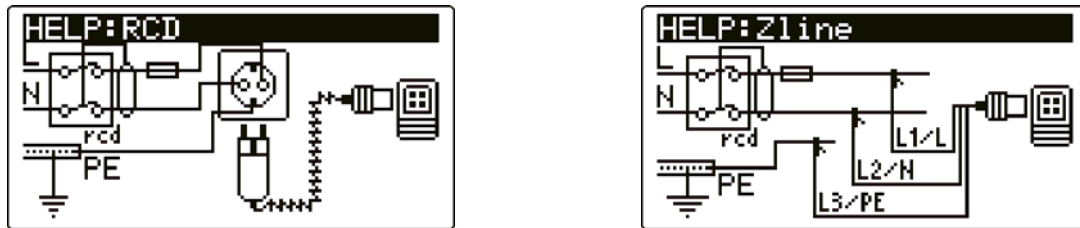

Figure 3.6: Examples of help screens

3.4.7 Backlight and contrast adjustments

With the **BACKLIGHT** key backlight and contrast can be adjusted.

Click	Toggles backlight intensity level.
Keep pressed for 1 s	Locks high intensity backlight level until power is turned off or the key is pressed again.
Keep pressed for 2 s	Bargraph for LCD contrast adjustment is displayed.



Figure 3.7: Contrast adjustment menu

Keys for contrast adjustment:

DOWN	Reduces contrast.
UP	Increases contrast.
TEST	Accepts new contrast.
Function selectors	Exits without changes.

4 Instrument operation

4.1 Function selection

For selecting test function the **FUNCTION SELECTOR** shall be used.

Keys:

FUNCTION SELECTOR	Select test / measurement function: <ul style="list-style-type: none"> <input type="checkbox"/> <VOLTAGE TRMS> Voltage and frequency and phase sequence. <input type="checkbox"/> <R ISO> Insulation resistance. <input type="checkbox"/> <Continuity> Continuity of earth connections and bondings <input type="checkbox"/> <Zline> Line impedance. <input type="checkbox"/> <Zloop> Fault loop impedance. <input type="checkbox"/> <RCD> RCD testing. <input type="checkbox"/> <SETTINGS> General instrument settings.
UP/DOWN	Selects sub-function in selected measurement function.
TAB	Selects the test parameter to be set or modified.
TEST	Runs selected test / measurement function.

Keys in **test parameter** field:

UP/DOWN	Changes the selected parameter.
TAB	Selects the next measuring parameter.
FUNCTION SELECTOR	Toggles between the main functions.

General rule regarding enabling **parameters** for evaluation of measurement / test result:

Parameter	OFF	No limit values, indication: <u> </u> .
	ON	Value(s) – results will be marked as PASS or FAIL in accordance with selected limit.

See *Chapter 5* for more information about the operation of the instrument test functions.

4.2 Settings

Different instrument options can be set in the **SETTINGS** menu.

Options are:

- ❑ Selection of language,
- ❑ Setting the instrument to initial values,
- ❑ Selection of reference standard for RCD test,
- ❑ Entering Z factor
- ❑ Commander support.

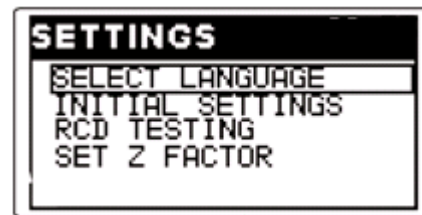

Figure 4.1: Options in Settings menu

Keys:

UP / DOWN	Selects appropriate option.
TEST	Enters selected option.
Function selectors	Exits back to main function menu.

4.2.1 Language

In this menu the language can be set.



Figure 4.2: Language selection

Keys:

UP / DOWN	Selects language.
TEST	Confirms selected language and exits to settings menu.
Function selectors	Exits back to main function menu.

4.2.2 Initial settings

In this menu the instrument settings and measurement parameters and limits can be set to initial (factory) values.

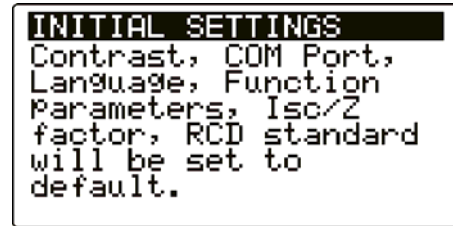

Figure 4.3: Initial settings dialogue

Keys:

TEST	Restores default settings.
Function selectors	Exits back to main function menu without changes.

Warning:

- ❑ Customized settings will be lost when this option is used!
- ❑ If the batteries are removed for more than 1 minute the custom made settings will be lost.

The default setup is listed below:

Instrument setting	Default value
Contrast	As defined and stored by adjustment procedure
Z factor	0.8
RCD standards	EN 61008 / EN 61009
Language	English
Commander	Enabled

Function Sub-function	Parameters / limit value
EARTH RE	No limit
R ISO	No limit U _{test} = 500 V
CONTINUITY	No limit
Z - LINE VOLTAGE DROP	Fuse type: none selected ΔU: 4.0 % Z _{REF} : 0.00 Ω
Z - LOOP	Fuse type: none selected
Z _{s rcd}	Fuse type: none selected
RCD	RCD t Nominal differential current: I _{ΔN} =30 mA RCD type: G Test current starting polarity:  (0°) Limit contact voltage: 50 V Current multiplier: ×1

Note:

- ❑ Initial settings (reset of the instrument) can be recalled also if the TAB key is pressed while the instrument is switched on.

4.2.3 RCD standard

In this menu the used standard for RCD tests can be set.

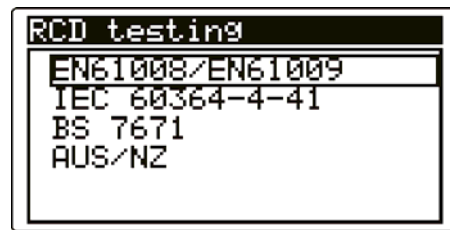

Figure 4.4: Selection of RCD test standard

Keys:

UP / DOWN	Selects standard.
TEST	Confirms selected standard.
Function selectors	Exits back to main function menu.

Maximum RCD disconnection times differ in various standards.
The trip-out times defined in individual standards are listed below.

Trip-out times according to EN 61008 / EN 61009:

	$\frac{1}{2} \times I_{\Delta N}^{*)}$	$I_{\Delta N}$	$2 \times I_{\Delta N}$	$5 \times I_{\Delta N}$
General RCDs (non-delayed)	$t_{\Delta} > 300$ ms	$t_{\Delta} < 300$ ms	$t_{\Delta} < 150$ ms	$t_{\Delta} < 40$ ms
Selective RCDs (time-delayed)	$t_{\Delta} > 500$ ms	130 ms $< t_{\Delta} < 500$ ms	60 ms $< t_{\Delta} < 200$ ms	50 ms $< t_{\Delta} < 150$ ms

Trip-out times according to EN 60364-4-41:

	$\frac{1}{2} \times I_{\Delta N}^{*)}$	$I_{\Delta N}$	$2 \times I_{\Delta N}$	$5 \times I_{\Delta N}$
General RCDs (non-delayed)	$t_{\Delta} > 999$ ms	$t_{\Delta} < 999$ ms	$t_{\Delta} < 150$ ms	$t_{\Delta} < 40$ ms
Selective RCDs (time-delayed)	$t_{\Delta} > 999$ ms	130 ms $< t_{\Delta} < 999$ ms	60 ms $< t_{\Delta} < 200$ ms	50 ms $< t_{\Delta} < 150$ ms

Trip-out times according to BS 7671:

	$\frac{1}{2} \times I_{\Delta N}^{*)}$	$I_{\Delta N}$	$2 \times I_{\Delta N}$	$5 \times I_{\Delta N}$
General RCDs (non-delayed)	$t_{\Delta} > 1999$ ms	$t_{\Delta} < 300$ ms	$t_{\Delta} < 150$ ms	$t_{\Delta} < 40$ ms
Selective RCDs (time-delayed)	$t_{\Delta} > 1999$ ms	130 ms $< t_{\Delta} < 500$ ms	60 ms $< t_{\Delta} < 200$ ms	50 ms $< t_{\Delta} < 150$ ms

Trip-out times according to AS/NZ^{**}):

RCD type	$I_{\Delta N}$ [mA]	$\frac{1}{2} \times I_{\Delta N}^{*)}$ t_{Δ}	$I_{\Delta N}$ t_{Δ}	$2 \times I_{\Delta N}$ t_{Δ}	$5 \times I_{\Delta N}$ t_{Δ}	Note
I	≤ 10	> 999 ms	40 ms	40 ms	40 ms	Maximum break time
II	$> 10 \leq 30$		300 ms	150 ms	40 ms	
III	> 30		300 ms	150 ms	40 ms	
IV S	> 30	> 999 ms	500 ms	200 ms	150 ms	Minimum non-actuating time
			130 ms	60 ms	50 ms	

^{*)} Minimum test period for current of $\frac{1}{2} \times I_{\Delta N}$, RCD shall not trip-out.

^{**)} Test current and measurement accuracy correspond to AS/NZ requirements.

Maximum test times related to selected test current for general (non-delayed) RCD

Standard	$\frac{1}{2} \times I_{\Delta N}$	$I_{\Delta N}$	$2 \times I_{\Delta N}$	$5 \times I_{\Delta N}$
EN 61008 / EN 61009	300 ms	300 ms	150 ms	40 ms
EN 60364-4-41	1000 ms	1000 ms	150 ms	40 ms
BS 7671	2000 ms	300 ms	150 ms	40 ms
AS/NZ (I, II, III)	1000 ms	1000 ms	150 ms	40 ms

Maximum test times related to selected test current for selective (time-delayed) RCD

Standard	$\frac{1}{2} \times I_{\Delta N}$	$I_{\Delta N}$	$2 \times I_{\Delta N}$	$5 \times I_{\Delta N}$
EN 61008 / EN 61009	500 ms	500 ms	200 ms	150 ms
EN 60364-4-41	1000 ms	1000 ms	200 ms	150 ms
BS 7671	2000 ms	500 ms	200 ms	150 ms
AS/NZ (IV)	1000 ms	1000 ms	200 ms	150 ms

4.2.4 Z factor

The impedance limit values for different overcurrent protective devices are scaled down by a factor 0,8 or 0,75 (Z factor). This means that the fault current will still be high enough also at increased conductor temperatures and low supply voltage. This assures a safe operation of the overcurrent protection device in all conditions.

In this menu the Z factor can be set.

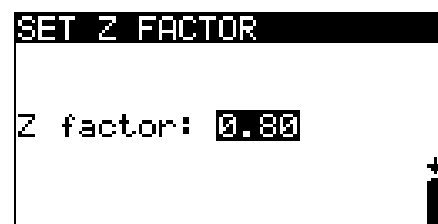

Figure 4.5: Selection of Z factor

Keys:

UP / DOWN	Sets Z value.
TEST	Confirms Z value.
Function selectors	Exits back to main function menu.

4.2.5 Commander support

The support for remote commanders can be switched On/ Off in this menu.

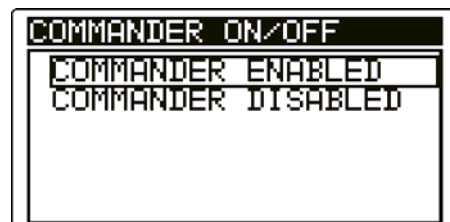

Figure 4.6: Selection of commander support

Keys:

UP / DOWN	Selects commander option.
TEST	Confirms selected option.
Function selectors	Exits back to main function menu.

Note:

- This option is intended to disable the commander's remote keys. In the case of high EM interfering noise the operation of the commander's key can be irregular.

5 Measurements

5.1 Voltage, frequency and phase sequence

In the special **VOLTAGE TRMS** menu the measured voltage, frequency and information about detected three-phase connection are displayed. Phase sequence measurement conforms to the EN 61557-7 standard.

See chapter 4.1 *Function selection* for instructions on key functionality.

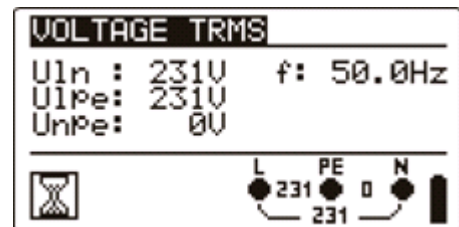

Figure 5.1: Voltage in single phase system

Test parameters for voltage measurement

There are no parameters to set.

Connections for voltage measurement

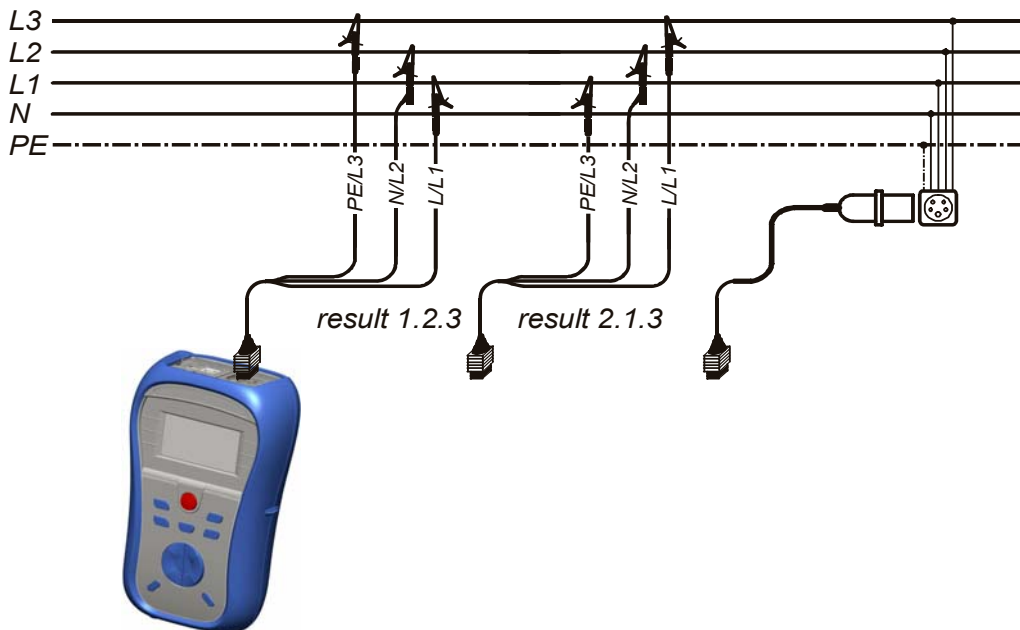

Figure 5.2: Connection of universal test cable and optional adapter in three-phase system

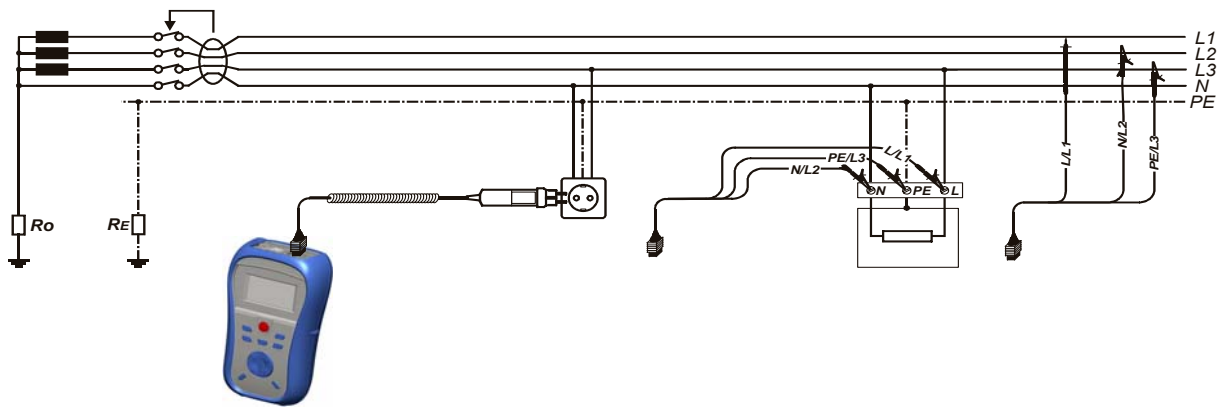

Figure 5.3: Connection of plug cable and universal test cable in single-phase system

Voltage measurement procedure

- ❑ Select the **VOLTAGE TRMS** function using the function selector switch.
- ❑ **Connect** test cable to the instrument.
- ❑ **Connect** test leads to the item to be tested (see figures 5.2 and 5.3).

Measurement runs immediately after selection of **VOLTAGE TRMS** function.



Figure 5.4: Examples of voltage measurement in three-phase system

Displayed results for single phase system:

- U_{ln}..... Voltage between phase and neutral conductors,
- U_{lpe}..... Voltage between phase and protective conductors,
- U_{npe}..... Voltage between neutral and protective conductors,
- f..... frequency.

Displayed results for three-phase system:

- U₁₂..... Voltage between phases L1 and L2,
- U₁₃..... Voltage between phases L1 and L3,
- U₂₃..... Voltage between phases L2 and L3,
- 1.2.3 Correct connection – CW rotation sequence,
- 3.2.1 Invalid connection – CCW rotation sequence,
- f..... frequency.

5.2 Insulation resistance

The Insulation resistance measurement is performed in order to ensure safety against electric shock through insulation. It is covered by the EN 61557-2 standard. Typical applications are:

- Insulation resistance between conductors of installation,
- Insulation resistance of non-conductive rooms (walls and floors),
- Insulation resistance of ground cables,
- Resistance of semi-conductive (antistatic) floors.

See chapter 4.1 *Function selection* for instructions on key functionality.



Figure 5.5: Insulation resistance

Test parameters for insulation resistance measurement

Uiso	Test voltage [50 V, 100 V, 250 V, 500 V, 1000 V]
Limit	Minimum insulation resistance [OFF, 0.01 MΩ ÷ 200 MΩ]

Test circuits for insulation resistance

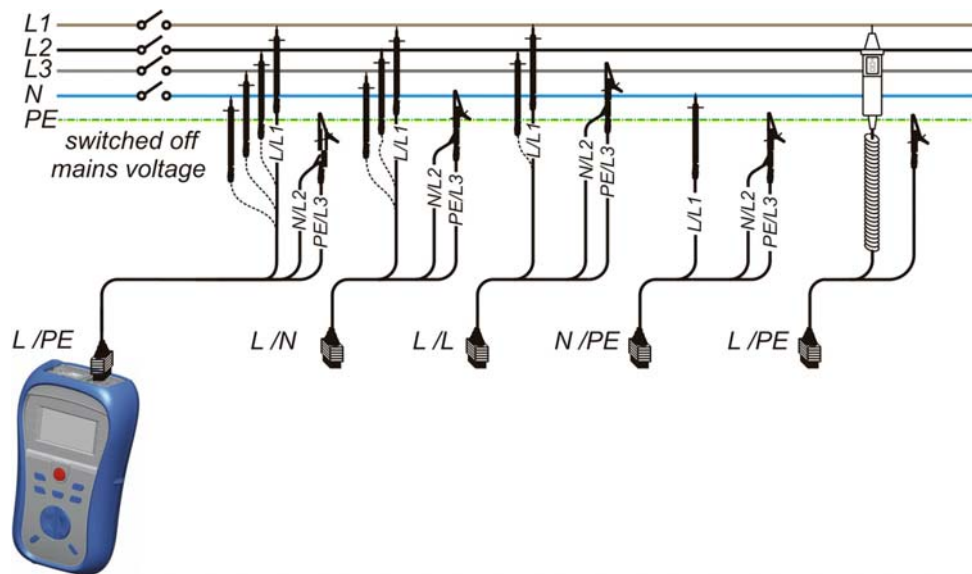

Figure 5.6: Connections for insulation measurement

Insulation resistance measuring procedure

- ❑ Select the **INS** function using the function selector switch.
- ❑ Set the required **test voltage**.
- ❑ Enable and set **limit** value (optional).
- ❑ **Disconnect** tested installation from mains supply (and discharge insulation as required).
- ❑ **Connect** test cable to the instrument and to the item to be tested (see figure 5.6).
- ❑ Press the **TEST** key to perform the measurement (double click for continuous measurement and later press to stop the measurement).
- ❑ After the measurement is finished wait until tested item is fully discharged.

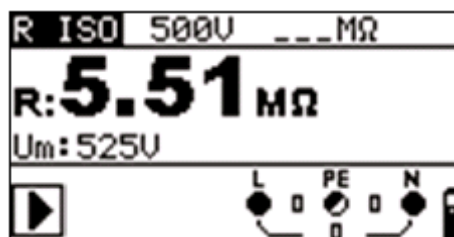

Figure 5.7: Example of insulation resistance measurement result

Displayed results:

R.....Insulation resistance
 Um.....Test voltage – actual value.

5.3 Continuity

The Continuity measurement is performed in order to ensure that the protective measures against electric shock through earthing connections and bondings are effective.

See chapter 4.1 *Function selection* for instructions on key functionality.

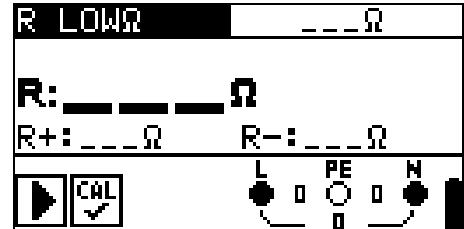

Figure 5.8: 200 mA RLOW Ω

Test parameters for Continuity measurement

Limit	Maximum resistance [OFF, 0.1 Ω ÷ 20.0 Ω]
-------	--

The Continuity measurement is performed with automatic polarity reversal of the test voltage according to IEC/EN 61557-4.

Test circuits for Continuity measurement

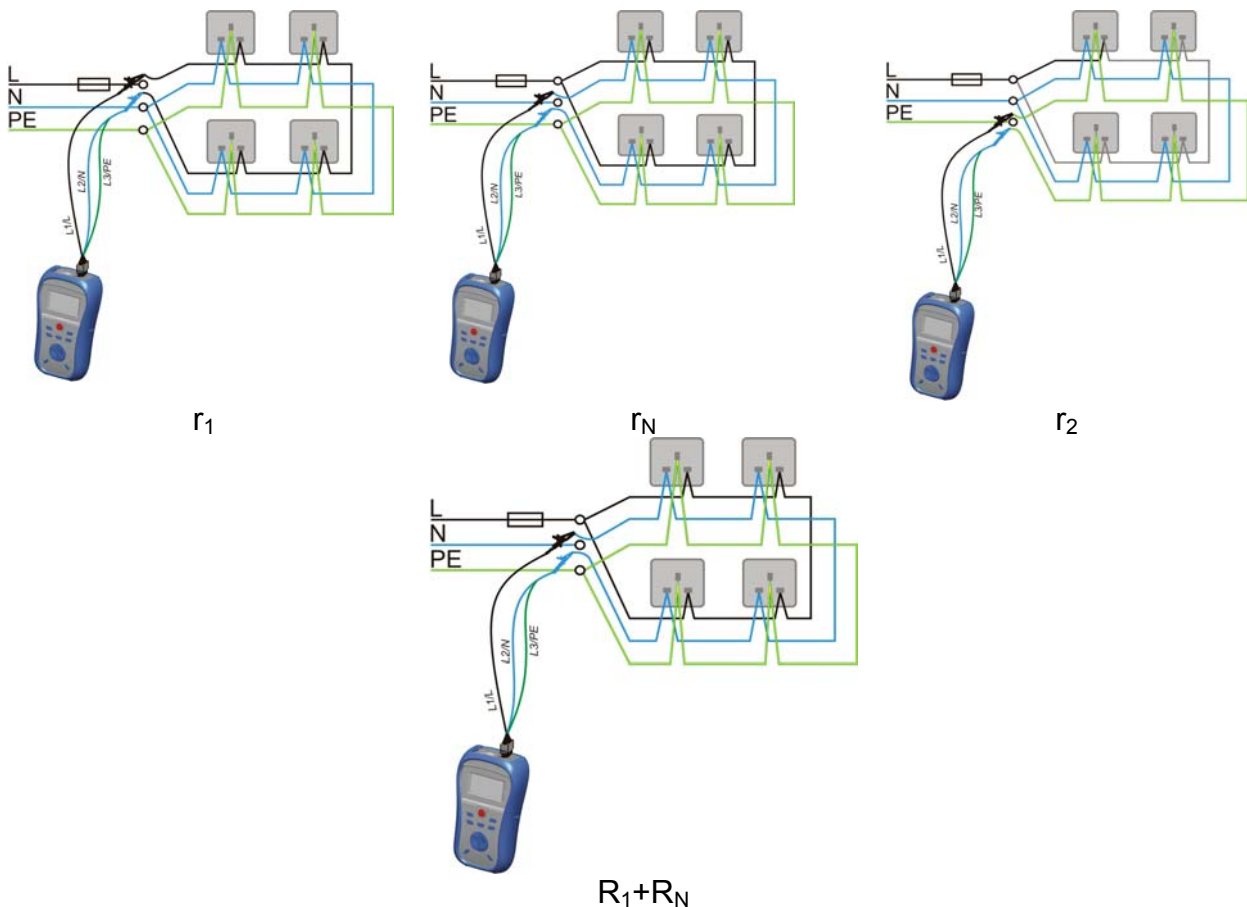

Figure 5.9: Connections for testing the r_1 , r_N , r_2 and R_1+R_N sections of the wiring in ring circuits

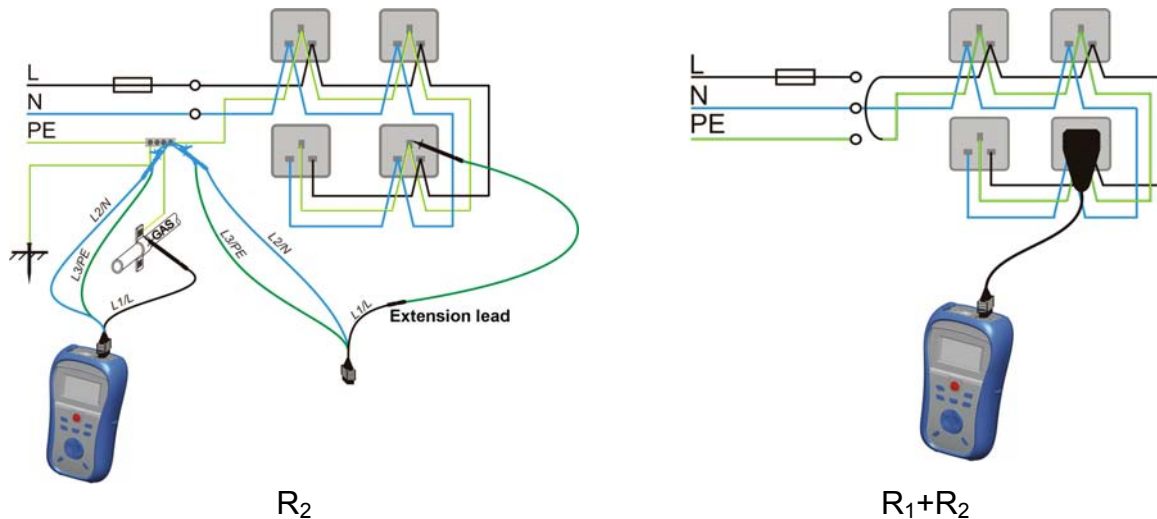

Figure 5.10: Connections for testing the R_2 and R_1+R_2 sections of the wiring in final circuits

Continuity measurement procedure

- ❑ Select **Continuity** function using the function selector switch.
- ❑ Enable and set **limit** (optional).
- ❑ **Connect** test cable to the the instrument.
- ❑ **Compensate** the test leads resistance (if necessary, see section 5.3.1).
- ❑ **Disconnect** from mains supply and discharge installation to be tested.
- ❑ **Connect** the test leads to the appropriate PE wiring (see figures 5.9 and 5.10).
- ❑ Press the **TEST** key to perform the measurement.

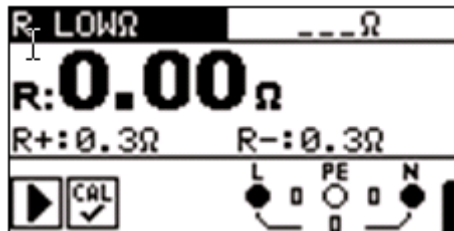



Figure 5.11: Example of $R_{LOW\Omega}$ result

Displayed result:

- R.....Continuity result
- R+.....Result at positive polarity
- R-.....Result at negative test polarity

5.3.1 Compensation of test leads resistance

This chapter describes how to compensate the test leads resistance in Continuity function. Compensation is required to eliminate the influence of test leads resistance and the internal resistances of the instrument on the measured resistance. The lead compensation is therefore very important to obtain correct result.

The  symbol is displayed in the Continuity message fields if the compensation was carried out successfully.

Circuits for compensating the resistance of test leads

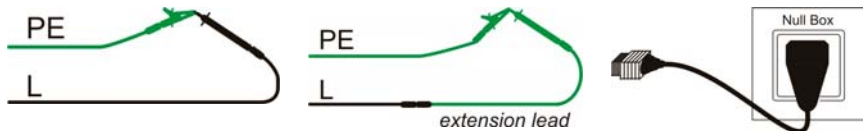

Figure 5.12: Shorted test leads

Compensation of test leads resistance procedure

- ❑ Select **Continuity** function.
- ❑ **Connect** test cable to the instrument and short the test leads together appropriately (see figure 5.12).
- ❑ Press **CAL** key to perform test lead compensation.
- ❑ If the leads were successfully calibrated the resistance with old calibration data is displayed first and 0.00Ω afterwards.

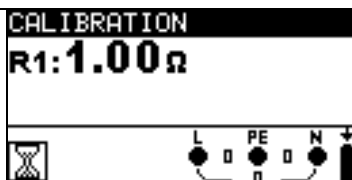

Figure 5.13: Results with old calibration values

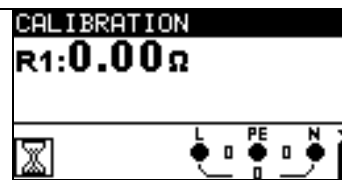



Figure 5.14: Results with new calibration values

Note:

- ❑ The highest value for lead compensation is 5 Ω. If the resistance is higher the compensation value is set back to default value.

 is displayed if no calibration value is stored.

5.4 Testing RCDs

Various test and measurements are required for verification of RCD(s) in RCD protected installations. Measurements are based on the EN 61557-6 standard.

The following measurements and tests (sub-functions) can be performed:

- Contact voltage,
- Trip-out time,
- Trip-out current,
- RCD autotest.

See chapter 4.1 *Function selection* for instructions on key functionality.

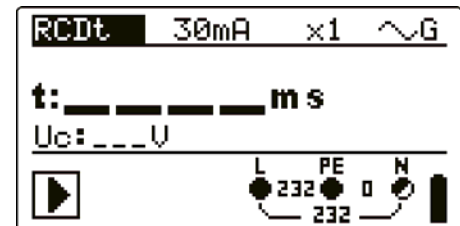

Figure 5.13: RCD test

Test parameters for RCD test and measurement

TEST	RCD sub-function test [RCDt, RCD I, AUTO, Uc].
$I_{\Delta N}$	Rated RCD residual current sensitivity $I_{\Delta N}$ [10 mA, 30 mA, 100 mA, 300 mA, 500 mA, 1000 mA].
type	RCD type [G , S], test current waveform plus starting polarity [\sim , \sim , \sim , \sim].
MUL	Multiplication factor for test current [$\frac{1}{2}$, 1, 2, 5 $I_{\Delta N}$].
Ulim	Conventional touch voltage limit [25 V, 50 V].

Notes:

- Ulim can be selected in the Uc sub-function only.

The instrument is intended for testing of **G**eneral (non-delayed) and **S**elective (time-delayed) RCDs, which are suited for:

- Alternating residual current (AC type, marked with \sim symbol),
- Pulsating residual current (A type, marked with \sim symbol).
- Pulsating residual current (A type, marked with \sim symbol).

Time delayed RCDs have delayed response characteristics. As the contact voltage pre-test or other RCD tests influence the time delayed RCD it takes a certain period to recover into normal state. Therefore a time delay of 30 s is inserted before performing trip-out test by default.

Connections for testing RCD

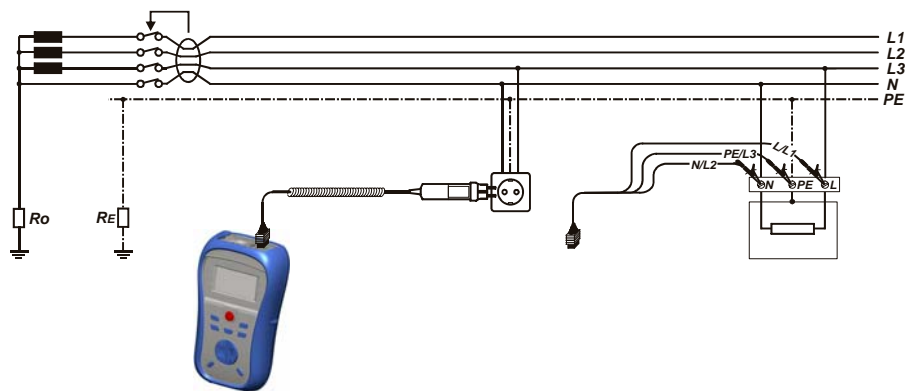

Figure 5.14: Connecting the plug cable and the universal test cable

5.4.1 Contact voltage (RCD U_c)

A current flowing into the PE terminal causes a voltage drop on earth resistance, i.e. voltage difference between PE equipotential bonding circuit and earth. This voltage difference is called contact voltage and is present on all accessible conductive parts connected to the PE. It shall always be lower than the conventional safety limit voltage. The contact voltage is measured with a test current lower than $\frac{1}{2} I_{\Delta N}$ to avoid trip-out of the RCD and then normalized to the rated $I_{\Delta N}$.

Contact voltage measurement procedure

- ❑ Select the **RCD** function using the function selector switch.
- ❑ Set sub-function **U_c**.
- ❑ Set test **parameters** (if necessary).
- ❑ **Connect** test cable to the instrument.
- ❑ **Connect** test leads to the item to be tested (see figure 5.16).
- ❑ Press the **TEST** key to perform the measurement.

The contact voltage result relates to the rated nominal residual current of the RCD and is multiplied by an appropriate factor (depending on RCD type and type of test current). The 1.05 factor is applied to avoid negative tolerance of result. See table 5.1 for detailed contact voltage calculation factors.

RCD type		Contact voltage U_c proportional to	Rated $I_{\Delta N}$	
AC	G	$1.05 \times I_{\Delta N}$	any	Both models
AC	S	$2 \times 1.05 \times I_{\Delta N}$		
A	G	$1.4 \times 1.05 \times I_{\Delta N}$	$\geq 30 \text{ mA}$	
A	S	$2 \times 1.4 \times 1.05 \times I_{\Delta N}$		
A	G	$2 \times 1.05 \times I_{\Delta N}$	$< 30 \text{ mA}$	
A	S	$2 \times 2 \times 1.05 \times I_{\Delta N}$		

Table 5.1: Relationship between U_c and $I_{\Delta N}$

Loop resistance is indicative and calculated from U_c result (without additional proportional factors) according to: $R_L = \frac{U_c}{I_{\Delta N}}$.

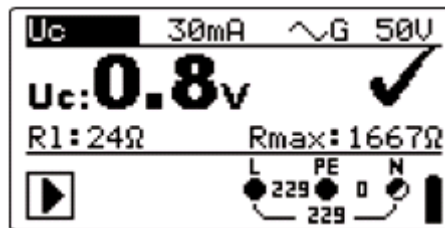

Figure 5.15: Example of contact voltage measurement results

Displayed results:

U_cContact voltage.

R_1Fault loop resistance.

R_{max} ...Maximum earth fault loop resistance value according to BS 7671

5.4.2 Trip-out time (RCDt)

Trip-out time measurement verifies the sensitivity of the RCD at different residual currents.

Trip-out time measurement procedure

- Select the **RCD** function using the function selector switch.
- Set sub-function **RCDt**.
- Set test **parameters** (if necessary).
- Connect** test cable to the instrument.
- Connect** test leads to the item to be tested (see *figure 5.16*).
- Press the **TEST** key to perform the measurement.

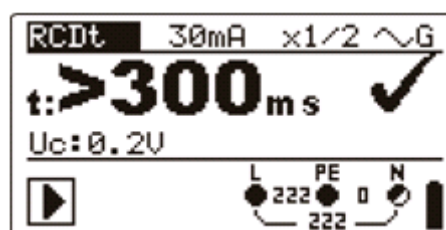

Figure 5.16: Example of trip-out time measurement results

Displayed results:

tTrip-out time,

U_cContact voltage for rated $I_{\Delta N}$.

5.4.3 Trip-out current (RCD I)

A continuously rising residual current is intended for testing the threshold sensitivity for RCD trip-out. The instrument increases the test current in small steps through appropriate range as follows:

RCD type	Slope range		Waveform	Note
	Start value	End value		
AC	$0.2 \times I_{\Delta N}$	$1.1 \times I_{\Delta N}$	Sine	Both models
A ($I_{\Delta N} \geq 30 \text{ mA}$)	$0.2 \times I_{\Delta N}$	$1.5 \times I_{\Delta N}$	Pulsed	
A ($I_{\Delta N} = 10 \text{ mA}$)	$0.2 \times I_{\Delta N}$	$2.2 \times I_{\Delta N}$		

Maximum test current is I_{Δ} (trip-out current) or end value in case the RCD didn't trip-out.

Trip-out current measurement procedure

- ❑ Select the **RCD** function using the function selector switch.
- ❑ Set sub-function **RCD I**.
- ❑ Set test **parameters** (if necessary).
- ❑ **Connect** test cable to the instrument.
- ❑ **Connect** test leads to the item to be tested (see *figure 5.16*).
- ❑ Press the **TEST** key to perform the measurement.

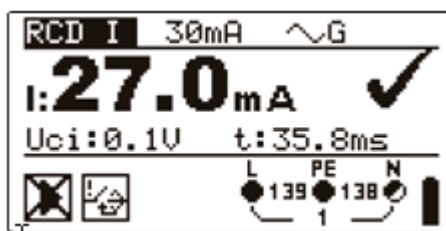

Trip-out

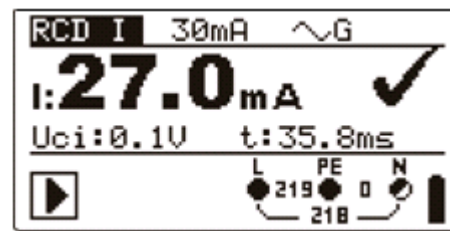

After the RCD is turned on again

Figure 5.17: Trip-out current measurement result example

Displayed results:

I Trip-out current,

Uci Contact voltage at trip-out current I or end value in case the RCD didn't trip,

t Trip-out time.

5.4.4 RCD Autotest

RCD autotest function is intended to perform a complete RCD test (trip-out time at different residual currents, trip-out current and contact voltage) in one set of automatic tests, guided by the instrument.

Additional key:

HELP / DISPLAY

Toggles between top and bottom part of results field.

RCD autotest procedure

RCD Autotest steps	Notes
<ul style="list-style-type: none"> □ Select the RCD function using the function selector switch. □ Set sub-function AUTO. □ Set test parameters (if necessary). □ Connect test cable to the instrument. □ Connect test leads to the item to be tested (see <i>figure 5.16</i>). □ Press the TEST key to perform the test. 	Start of test
<ul style="list-style-type: none"> □ Test with $I_{\Delta N}$, 0° (step 1). 	RCD should trip-out
<ul style="list-style-type: none"> □ Re-activate RCD. □ Test with $I_{\Delta N}$, 180° (step 2). 	RCD should trip-out
<ul style="list-style-type: none"> □ Re-activate RCD. □ Test with $5 \times I_{\Delta N}$, 0° (step 3). 	RCD should trip-out
<ul style="list-style-type: none"> □ Re-activate RCD. □ Test with $5 \times I_{\Delta N}$, 180° (step 4). 	RCD should trip-out
<ul style="list-style-type: none"> □ Re-activate RCD. □ Test with $\frac{1}{2} \times I_{\Delta N}$, 0° (step 5). □ Test with $\frac{1}{2} \times I_{\Delta N}$, 180° (step 6). 	RCD should not trip-out RCD should not trip-out
<ul style="list-style-type: none"> □ Trip-out current test, 0° (step 7). 	RCD should trip-out
<ul style="list-style-type: none"> □ Re-activate RCD. □ Trip-out current test, 180° (step 8). □ Re-activate RCD. 	RCD should trip-out

Result examples:

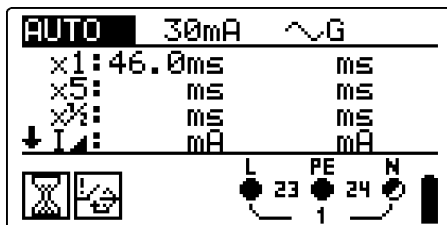

Step 1

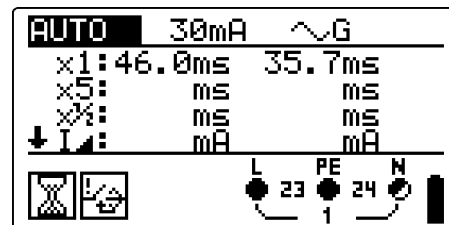

Step 2

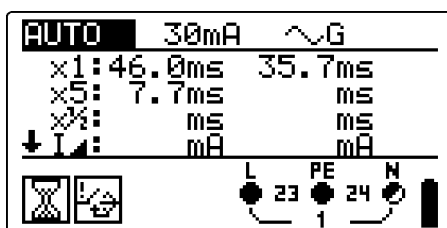

Step 3

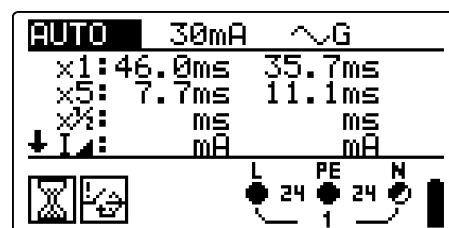

Step 4

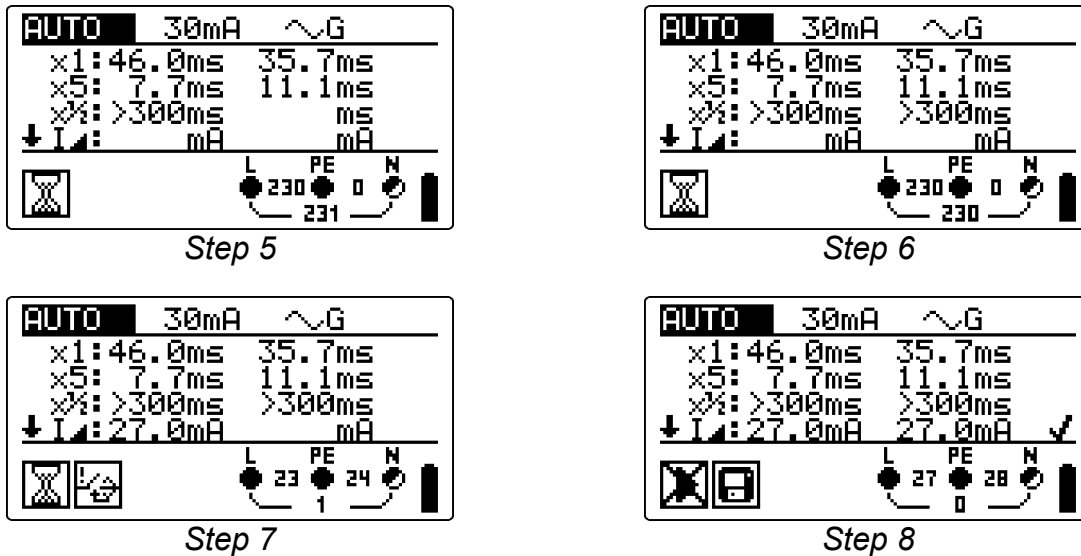

Figure 5.18: Individual steps in RCD autotest

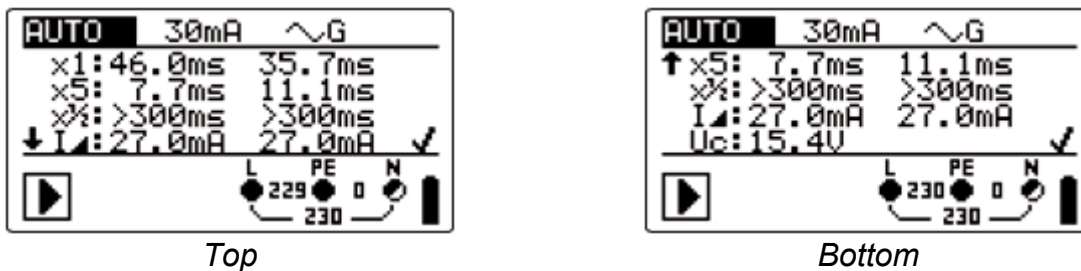

Figure 5.19: Two parts of result field in RCD autotest

Displayed results:

- x1 Step 1 trip-out time (t_{x1}^0 , $I_{\Delta N}$, 0°),
- x1 Step 2 trip-out time (t_{x1}^{180} , $I_{\Delta N}$, 180°),
- x5 Step 3 trip-out time (t_{x5}^0 , $5 \times I_{\Delta N}$, 0°),
- x5 Step 4 trip-out time (t_{x5}^{180} , $5 \times I_{\Delta N}$, 180°),
- x1/2 Step 5 trip-out time ($t_{x1/2}^0$, $\frac{1}{2} \times I_{\Delta N}$, 0°),
- x1/2 Step 6 trip-out time ($t_{x1/2}^{180}$, $\frac{1}{2} \times I_{\Delta N}$, 180°),
- IΔ Step 7 trip-out current (0°),
- IΔ Step 8 trip-out current (180°),
- Uc Contact voltage for rated $I_{\Delta N}$.

Notes:

- The autotest sequence is immediately stopped if any incorrect condition is detected, e.g. excessive U_c or trip-out time out of bounds.
- Auto test is finished without x5 tests in case of testing the RCD type A with rated residual currents of $I_{\Delta n} = 300 \text{ mA}$, 500 mA , and 1000 mA . In this case auto test result passes if all other results pass, and indications for x5 are omitted.
- Tests for sensitivity (I_{Δ} , steps 7 and 8) are omitted for selective type RCD.

5.5 Fault loop impedance and prospective fault current

Fault loop is a loop comprised by mains source, line wiring and PE return path to the mains source. The instrument measures the impedance of the loop and calculates the short circuit current. The measurement is covered by requirements of the EN 61557-3 standard.

See chapter 4.1 *Function selection* for instructions on key functionality.



Figure 5.20: Fault loop impedance

Test parameters for fault loop impedance measurement

Test	Selection of fault loop impedance sub-function [Zloop, Zs rcd]
Fuse type	Selection of fuse type [---, BS88, BS3036, BS1361, BS1362, B, C, D]
Fuse I	Rated current of selected fuse
Fuse T	Maximum breaking time of selected fuse
Lim	Minimum short circuit current for selected fuse.

See Appendix A for reference fuse data.

Circuits for measurement of fault loop impedance

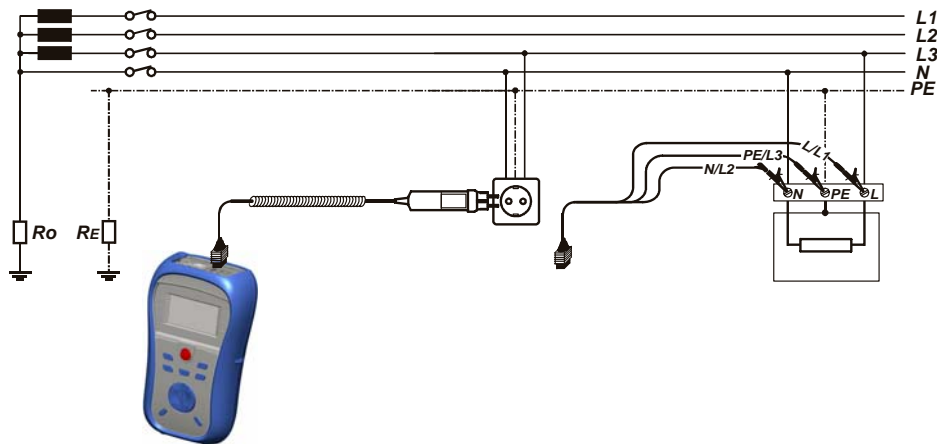

Figure 5.21: Connection of plug cable and universal test cable

Fault loop impedance measurement procedure

- ❑ Select the **Zloop** or **Zs rcd** subfunction using the function selector switch and $\blacktriangle/\blacktriangledown$ keys.
- ❑ Select test **parameters** (optional).
- ❑ **Connect** test cable the Eurotest Combo.
- ❑ **Connect** test leads to the the item to be tested (see *figure 5.23 and 5.16*).
- ❑ Press the **TEST** key to perform the measurement.



Figure 5.22: Examples of loop impedance measurement result

Displayed results:

Z..... Fault loop impedance,

Isc..... Prospective fault current,

Lim High limit fault loop impedance value.

Prospective fault current I_{PFC} is calculated from measured impedance as follows:

$$I_{PFC} = \frac{U_N}{Z_{L-PE} \cdot \text{scaling_factor}}$$

where:

U_nNominal U_{L-PE} voltage (see table below),

Scaling factor.....Impedance correction factor (see chapter 4.2.4).

U_n	Input voltage range (L-PE)
110 V	$(93 \text{ V} \leq U_{L-PE} < 134 \text{ V})$
230 V	$(185 \text{ V} \leq U_{L-PE} \leq 266 \text{ V})$

Notes:

- ❑ High fluctuations of mains voltage can influence the measurement results (the noise sign \square is displayed in the message field). In this case it is recommended to repeat few measurements to check if the readings are stable.
- ❑ The Zloop test will trip-out the RCD in RCD-protected electrical installation.
- ❑ Select Zs rcd to prevent trip-out of RCD in RCD protected installation.

5.6 Line impedance and prospective short-circuit current

Line impedance is a measurement of impedance comprising of the mains voltage source and line wiring. Line impedance is covered by the requirements of the EN 61557-3 standard.

The Voltage drop sub-function is intended to check that a voltage in the installation stays above acceptable levels if the highest current is flowing in the circuit. The highest current is defined as the nominal current of the circuit's fuse. The limit values are described in the standard EN 60364-5-52 (BS 7671 in the UK).

Sub-functions:

- Z LINE- Line impedance measurement according to EN 61557-3,
- ΔU – Voltage drop measurement.

See chapter 4.1 *Function selection* for instructions on key functionality.

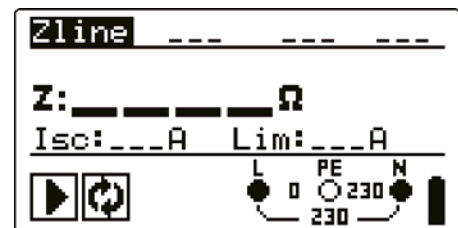

Figure 5.25: Line impedance

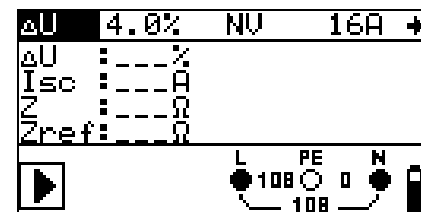

Figure 5.26: Voltage drop

Test parameters for line impedance measurement

Test	Selection of line impedance [Zline] or voltage drop [ΔU] sub-function
FUSE type	Selection of fuse type [---, BS88, BS3036, BS1361, BS1362, B, C, D]
FUSE I	Rated current of selected fuse
FUSE T	Maximum breaking time of selected fuse
Lim	Minimum short circuit current for selected fuse.

See Appendix A for reference fuse data.

Additional test parameters for voltage drop measurement

ΔU_{MAX}	Maximum voltage drop found during test [3.0 % ÷ 9.0 %].
------------------	--

5.6.1 Line impedance and prospective short circuit current

Circuits for measurement of line impedance

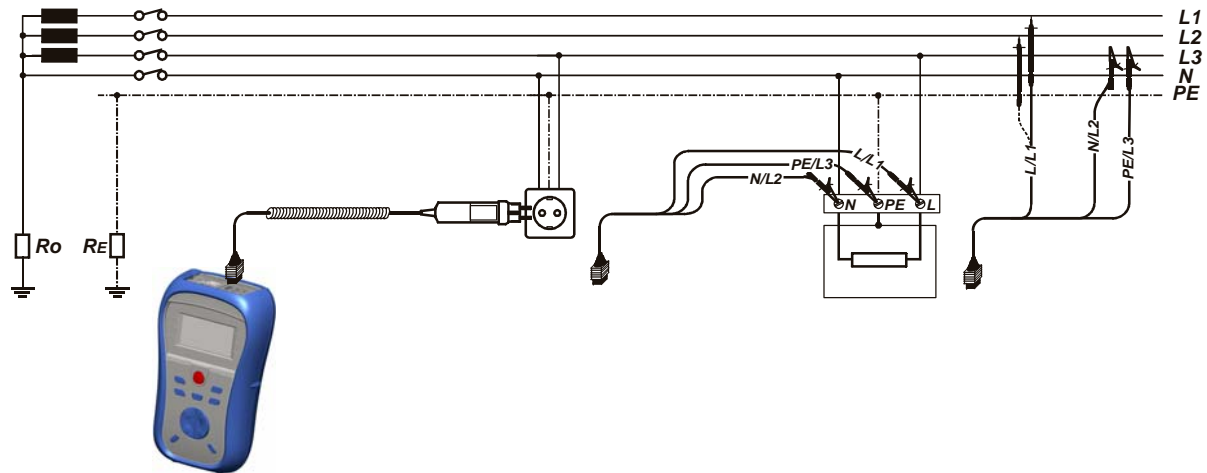
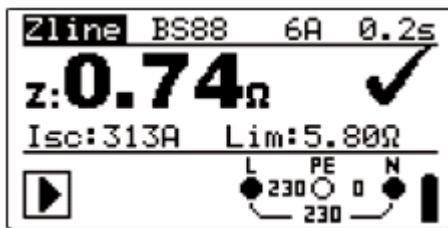

Figure 5.27: Phase-neutral or phase-phase line impedance measurement – connection of plug cable and universal test cable

Line impedance measurement procedure

- ❑ Select the **Z-LINE** function using the function selector switch.
- ❑ Select test **parameters** (optional).
- ❑ **Connect** test cable to the instrument.
- ❑ **Connect** test leads to the item to be tested (see figure 5.27).
- ❑ Press the **TEST** key to perform the measurement.



Line to neutral

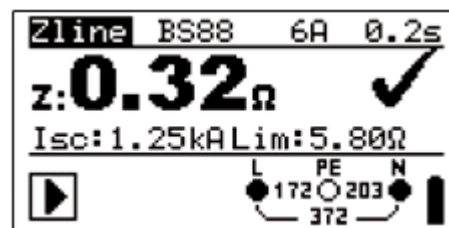

Line to line

Figure 5.28: Examples of line impedance measurement result

Displayed results:

- Z.....Line impedance,
- Isc.....Prospective short-circuit current,
- LimHigh limit line impedance value.

Prospective short circuit current I_{PSC} is calculated as follows:

$$I_{PSC} = \frac{U_N}{Z_{L-N(L)} \cdot scaling_factor}$$

where:

- UnNominal L-N or L1-L2 voltage (see table below),
- Scaling factor.....Impedance correction factor (see chapter 4.2.6).

U_n	Input voltage range (L-N or L1-L2)
110 V	$(93 \text{ V} \leq U_{L-PE} < 134 \text{ V})$
230 V	$(185 \text{ V} \leq U_{L-PE} \leq 266 \text{ V})$
400 V	$(321 \text{ V} < U_{L-N} \leq 485 \text{ V})$

Note:

- High fluctuations of mains voltage can influence the measurement results (the noise sign  is displayed in the message field). In this case it is recommended to repeat few measurements to check if the readings are stable.

5.6.2 Voltage drop

The voltage drop is calculated based on the difference of line impedance at connection points (sockets) and the line impedance at the reference point (usually the impedance at the switchboard).

Circuits for measurement for voltage drop

Figure 5.29: Phase-neutral or phase-phase voltage drop measurement – connection of plug commander and 3-wire test lead

Voltage drop measurement procedure**Step 1: Measuring the impedance Z_{ref} at origin**

- Select the **ΔU** sub-function using the function selector switch and $\blacktriangle/\blacktriangledown$ keys.
- Select test **parameters** (optional).
- **Connect** test cable to the instrument.
- **Connect** the test leads to the origin of electrical installation (see figure 5.29).
- Press the **CAL** key to perform the measurement.

Step 2: Measuring the voltage drop

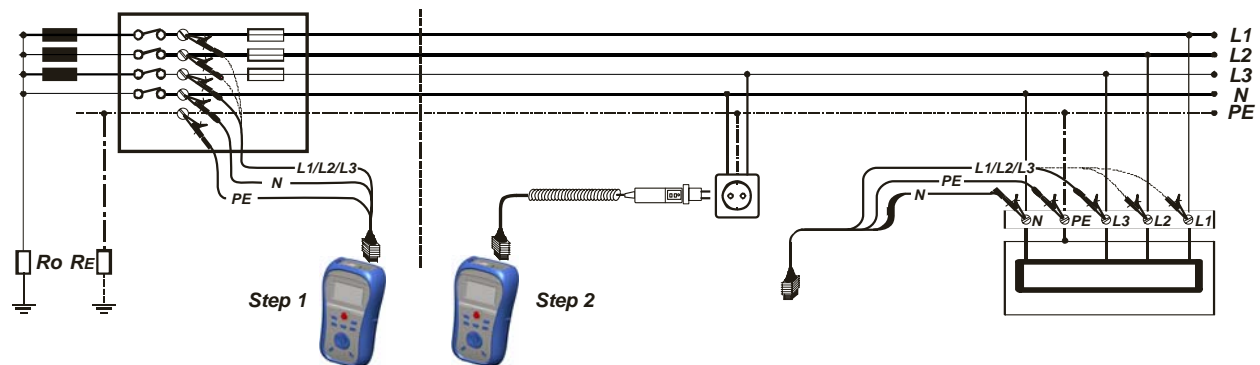
- Select the **ΔU** sub-function using the function selector switch and $\blacktriangle/\blacktriangledown$ keys.
- Select test **parameters** (Fuse type must be selected).
- **Connect** test cable or plug commander to the instrument.
- **Connect** the test leads to the tested points (see figure 5.29).
- Press the **TEST** key to perform the measurement.

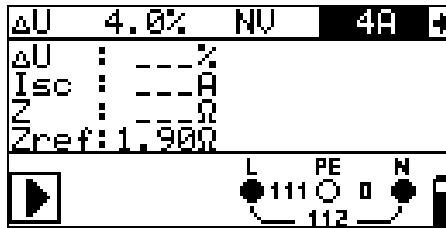

Step 1 - Zref

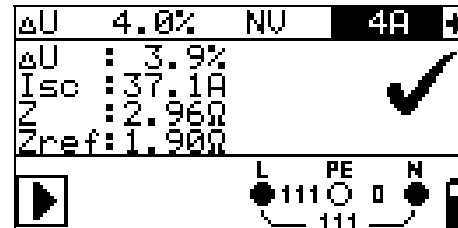

Step 2 - Voltage drop

Figure 5.30: Examples of voltage drop measurement result

Displayed results:

ΔU Voltage drop,

Isc Prospective short-circuit current,

Z Line impedance at measured point,

Zref Reference impedance

Voltage drop is calculated as follows:

$$\Delta U[\%] = \frac{(Z - Z_{REF}) \cdot I_N}{U_N} \cdot 100$$

where:

ΔU calculated voltage drop

Z impedance at test point

Z_{REF} impedance at reference point

I_N rated current of selected fuse

U_N nominal voltage (see table below)

U _n	Input voltage range (L-N or L1-L2)
110 V	(93 V ≤ U _{L-PE} < 134 V)
230 V	(185 V ≤ U _{L-PE} ≤ 266 V)
400 V	(321 V < U _{L-N} ≤ 485 V)

Note:

- If the reference impedance is not set the value of Z_{REF} is considered as 0.00 Ω.
- The Z_{REF} is cleared (set to 0.00 Ω) if pressing CAL key while instrument is not connected to a voltage source.
- I_{SC} is calculated as described in chapter 5.6.1 Line impedance and prospective short circuit current.
- If the measured voltage is outside the ranges described in the table above the ΔU result will not be calculated.
- High fluctuations of mains voltage can influence the measurement results (the noise sign  is displayed in the message field). In this case it is recommended to repeat few measurements to check if the readings are stable.

5.7 PE test terminal

It can happen that a dangerous voltage is applied to the PE wire or other accessible metal parts. This is a very dangerous situation since the PE wire and MPEs are considered to be earthed. An often reason for this fault is incorrect wiring (see examples below).

When touching the **TEST** key in all functions that require mains supply the user automatically performs this test.

Examples for application of PE test terminal

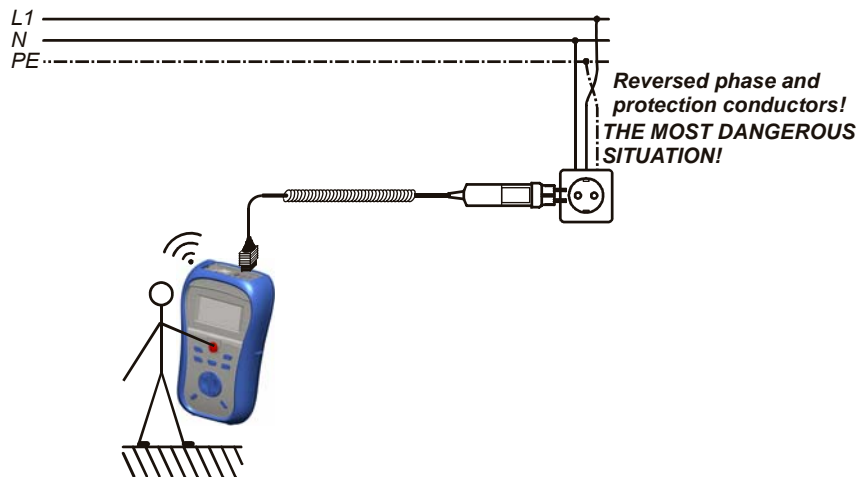

Figure 5.31: Reversed L and PE conductors (application of plug cable)

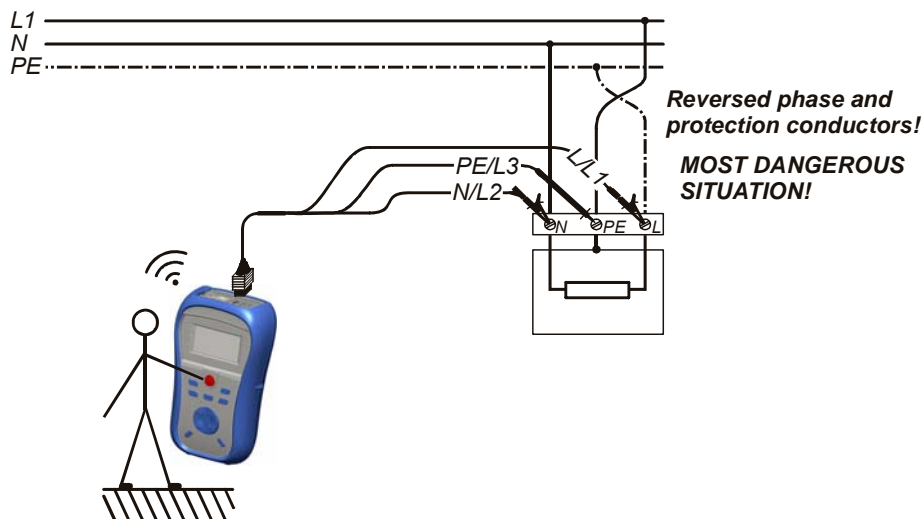

Figure 5.32: Reversed L and PE conductors (application of universal test cable)

PE terminal test procedure

- ❑ **Connect** test cable to the instrument.
- ❑ **Connect** test leads to the item to be tested (see *figures 5.31 and 5.32*).
- ❑ Touch PE test probe (the **TEST** key) for at least one second.
- ❑ If PE terminal is connected to phase voltage the warning message is displayed, instrument buzzer is activated, and further measurements are disabled in Z-LOOP and RCD functions.

Warning:

- ❑ If dangerous voltage is detected on the tested PE terminal, immediately stop all measurements, find and remove the fault!

Notes:

- ❑ In the SETTINGS and VOLTAGE TRMS menus the PE terminal is not tested.
- ❑ PE test terminal does not operate in case the operator's body is completely insulated from floor or walls!

6 Maintenance

Unauthorized persons are not allowed to open the Eurotest Combo instrument. There are no user replaceable components inside the instrument, except the battery and fuse under rear cover.

6.1 Fuse replacement

There is a fuse under back cover of the Eurotest Combo instrument.

- F1
M 0.315 A / 250 V, 20×5 mm
This fuse protects internal circuitry for continuity functions if test probes are connected to the mains supply voltage by mistake during measurement.

Warnings:

-  **Disconnect all measuring accessory and switch off the instrument before opening battery / fuse compartment cover, hazardous voltage inside!**
- Replace blown fuse with original type only, otherwise the instrument may be damaged and/or operator's safety impaired!

Position of fuses can be seen in *Figure 3.4* in chapter 3.3 *Back side*.

6.2 Cleaning

No special maintenance is required for the housing. To clean the surface of the instrument use a soft cloth slightly moistened with soapy water or alcohol. Then leave the instrument to dry totally before use.

Warnings:

- Do not use liquids based on petrol or hydrocarbons!
- Do not spill cleaning liquid over the instrument!

6.3 Periodic calibration

It is essential that the test instrument is regularly calibrated in order that the technical specification listed in this manual is guaranteed. We recommend an annual calibration. Only an authorized technical person can do the calibration. Please contact your dealer for further information.

6.4 Upgrading the instrument

The instrument can be upgraded from a PC via the RS232 communication port. This enables to upgrade the instrument to the latest available software version. The upgrade can be carried with help of a special upgrading software and the communication cable as shown on *Figure 6.14*. Please contact your dealer for more information.

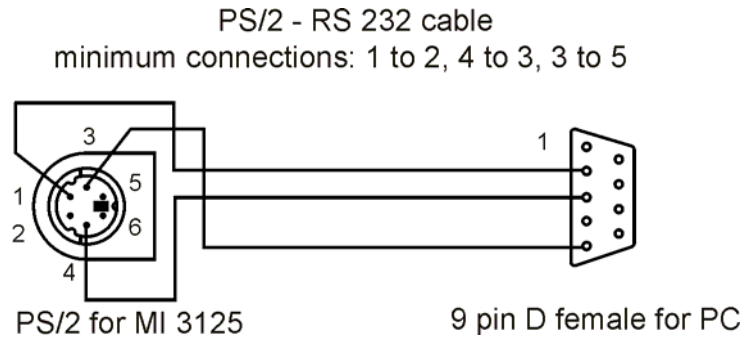

Figure 6.1: Interface connection for data transfer over PC COM port

6.5 Service

For repairs under warranty, or at any other time, please contact your distributor.

7 Technical specifications

7.1 Insulation resistance

Insulation resistance (nominal voltages 50 V_{DC}, 100 V_{DC} and 250 V_{DC})

Measuring range according to EN61557 is 0.25 MΩ ÷ 199.9 MΩ.

Measuring range (MΩ)	Resolution (MΩ)	Accuracy
0.00 ÷ 19.99	0.01	±(5 % of reading + 3 digits)
20.0 ÷ 99.9	0.1	±(10 % of reading)
100.0 ÷ 199.9		±(20 % of reading)

Insulation resistance (nominal voltages 500 V_{DC} and 1000 V_{DC})

Measuring range according to EN61557 is 0.15 MΩ ÷ 1 GΩ.

Measuring range (Ω)	Resolution (MΩ)	Accuracy
0.00M ÷ 19.99M	0.01	±(5 % of reading + 3 digits)
20.0M ÷ 199.9M	0.1	±(5 % of reading)
200M ÷ 999M	1	±(10 % of reading)

Voltage

Measuring range (V)	Resolution (V)	Accuracy
0 ÷ 1200	1	±(3 % of reading + 3 digits)

Nominal voltages50 V_{DC}, 100 V_{DC}, 250 V_{DC}, 500 V_{DC}, 1000 V_{DC}

Open circuit voltage-0 % / +20 % of nominal voltage

Measuring current.....min. 1 mA at R_N=U_N×1 kΩ/V

Short circuit current..... max. 3 mA

The number of possible tests..... > 1200, with a fully charged battery

Auto discharge after test.

Specified accuracy is valid up to 100 MΩ if relative humidity > 85 %.

In case the instrument gets moistened, the results could be impaired. In such case, it is recommended to dry the instrument and accessories for at least 24 hours.

The error in operating conditions could be at most the error for reference conditions (specified in the manual for each function) ±5 % of measured value.

7.2 Continuity

Measuring range according to EN61557 is 0.16 Ω ÷ 1999 Ω.

Measuring range R (Ω)	Resolution (Ω)	Accuracy
0.00 ÷ 19.99	0.01	±(3 % of reading + 3 digits)
20.0 ÷ 199.9	0.1	±(5 % of reading)
200 ÷ 1999	1	

Open-circuit voltage6.5 VDC ÷ 9 VDC

Measuring current.....min. 200 mA into load resistance of 2 Ω

Test lead compensation.....up to 5 Ω

The number of possible tests> 2000, with a fully charged battery

Automatic polarity reversal of the test voltage.

7.3 RCD testing

7.3.1 General data

Nominal residual current (A,AC) 10 mA, 30 mA, 100 mA, 300 mA, 500 mA, 1000 mA
 Nominal residual current accuracy.....-0 / +0.1·I Δ ; I Δ = I Δ N, 2×I Δ N, 5×I Δ N
 -0.1·I Δ / +0; I Δ = 0.5×I Δ N
 AS / NZ selected: \pm 5 %
 Test current shape.....Sine-wave (AC), pulsed (A)
 DC offset for pulsed test current6 mA (typical)
 RCD typeG (non-delayed), S (time-delayed)
 Test current starting polarity 0 ° or 180 °
 Voltage range93 V ÷ 266 V (45 Hz ÷ 65 Hz)

I Δ N (mA)	I Δ N × 1/2		I Δ N × 1		I Δ N × 2		I Δ N × 5		RCD I Δ	
	AC	A	AC	A	AC	A	AC	A	AC	A
10	5	3.5	10	20	20	40	50	100	✓	✓
30	15	10.5	30	42	60	84	150	212	✓	✓
100	50	35	100	141	200	282	500	707	✓	✓
300	150	105	300	424	600	848	1500	n.a.	✓	✓
500	250	175	500	707	1000	1410	2500	n.a.	✓	✓
1000	500	350	1000	1410	2000	n.a.	n.a.	n.a.	✓	✓

n.a.....not applicable

AC type.....sine wave test current

A type.....pulsed current

7.3.2 Contact voltage RCD-Uc

Measuring range according to EN61557 is 20.0 V ÷ 31.0V for limit contact voltage 25V

Measuring range according to EN61557 is 20.0 V ÷ 62.0V for limit contact voltage 50V

Measuring range (V)	Resolution (V)	Accuracy
0.0 ÷ 19.9	0.1	(-0 % / +15 %) of reading \pm 10 digits
20.0 ÷ 99.9		(-0 % / +15 %) of reading

The accuracy is valid if mains voltage is stable during the measurement and PE terminal is free of interfering voltages.

Test current max. 0.5×I Δ N

Limit contact voltage 25 V, 50 V

Specified accuracy is valid for complete operating range.

7.3.3 Trip-out time

Complete measurement range corresponds to EN 61557 requirements.

Maximum measuring times set according to selected reference for RCD testing.

Measuring range (ms)	Resolution (ms)	Accuracy
0.0 ÷ 40.0	0.1	\pm 1 ms
0.0 ÷ max. time *	0.1	\pm 3 ms

* For max. time see normative references in 4.2.3 – this specification applies to max. time >40 ms.

Test current $\frac{1}{2}I_{\Delta N}$, $I_{\Delta N}$, $2I_{\Delta N}$, $5I_{\Delta N}$

$5I_{\Delta N}$ is not available for $I_{\Delta N}=1000$ mA (RCD type AC) or $I_{\Delta N} \geq 300$ mA (RCD type A).

$2I_{\Delta N}$ is not available for $I_{\Delta N}=1000$ mA (RCD type A)

Specified accuracy is valid for complete operating range.

7.3.4 Trip-out current

Trip-out current

Complete measurement range corresponds to EN 61557 requirements.

Measuring range I_{Δ}	Resolution I_{Δ}	Accuracy
$0.2 \times I_{\Delta N} \div 1.1 \times I_{\Delta N}$ (AC type)	$0.05 \times I_{\Delta N}$	$\pm 0.1 \times I_{\Delta N}$
$0.2 \times I_{\Delta N} \div 1.5 \times I_{\Delta N}$ (A type, $I_{\Delta N} \geq 30$ mA)	$0.05 \times I_{\Delta N}$	$\pm 0.1 \times I_{\Delta N}$
$0.2 \times I_{\Delta N} \div 2.2 \times I_{\Delta N}$ (A type, $I_{\Delta N} < 30$ mA)	$0.05 \times I_{\Delta N}$	$\pm 0.1 \times I_{\Delta N}$

Trip-out time

Measuring range (ms)	Resolution (ms)	Accuracy
0 ÷ 300	1	± 3 ms

Contact voltage

Measuring range (V)	Resolution (V)	Accuracy
0.0 ÷ 19.9	0.1	(-0 % / +15 %) of reading ± 10 digits
20.0 ÷ 99.9	0.1	(-0 % / +15 %) of reading

The accuracy is valid if mains voltage is stable during the measurement and PE terminal is free of interfering voltages.

Specified accuracy is valid for complete operating range.

7.4 Fault loop impedance and prospective fault current

7.4.1 No disconnecting device or FUSE selected

Fault loop impedance

Measuring range according to EN61557 is $0.25 \Omega \div 9.99k\Omega$.

Measuring range (Ω)	Resolution (Ω)	Accuracy
0.00 ÷ 9.99	0.01	$\pm(5\% \text{ of reading} + 5 \text{ digits})$
10.0 ÷ 99.9	0.1	
100 ÷ 999	1	$\pm 10\% \text{ of reading}$
1.00k ÷ 9.99k	10	

Prospective fault current (calculated value)

Measuring range (A)	Resolution (A)	Accuracy
0.00 ÷ 9.99	0.01	Consider accuracy of fault loop resistance measurement
10.0 ÷ 99.9	0.1	
100 ÷ 999	1	
1.00k ÷ 9.99k	10	
10.0k ÷ 23.0k	100	

The accuracy is valid if mains voltage is stable during the measurement.

Test current (at 230 V)..... 6.5 A (10 ms)
 Nominal voltage range..... 93 V ÷ 266 V (45 Hz ÷ 65 Hz)

7.4.2 RCD selected

Fault loop impedance

Measuring range according to EN61557 is 0.46 Ω ÷ 9.99 k Ω .

Measuring range (Ω)	Resolution (Ω)	Accuracy
0.00 ÷ 9.99	0.01	±(5 % of reading + 10 digits)
10.0 ÷ 99.9	0.1	
100 ÷ 999	1	± 10 % of reading
1.00k ÷ 9.99k	10	

Accuracy may be impaired in case of heavy noise on mains voltage

Prospective fault current (calculated value)

Measuring range (A)	Resolution (A)	Accuracy
0.00 ÷ 9.99	0.01	Consider accuracy of fault loop resistance measurement
10.0 ÷ 99.9	0.1	
100 ÷ 999	1	
1.00k ÷ 9.99k	10	
10.0k ÷ 23.0k	100	

Nominal voltage range..... 93 V ÷ 266 V (45 Hz ÷ 65 Hz)

No trip out of RCD.

R, XL values are indicative.

7.5 Line impedance and prospective short-circuit current / Voltage drop

Line impedance

Measuring range according to EN61557 is 0.25 Ω ÷ 9.99k Ω .

Measuring range (Ω)	Resolution (Ω)	Accuracy
0.00 ÷ 9.99	0.01	±(5 % of reading + 5 digits)
10.0 ÷ 99.9	0.1	
100 ÷ 999	1	± 10 % of reading
1.00k ÷ 9.99k	10	

Prospective short-circuit current (calculated value)

Measuring range (A)	Resolution (A)	Accuracy
0.00 ÷ 0.99	0.01	Consider accuracy of line resistance measurement
1.0 ÷ 99.9	0.1	
100 ÷ 999	1	
1.00k ÷ 99.99k	10	
100k ÷ 199k	1000	

Test current (at 230 V)..... 6.5 A (10 ms)

Nominal voltage range..... 30 V ÷ 500 V (45 Hz ÷ 65 Hz)

R, XL values are indicative.

Voltage drop (calculated value)

Measuring range (%)	Resolution (%)	Accuracy
0.0 ÷ 99.9	0.1	Consider accuracy of line impedance measurement(s)*

Z_{REF} measuring range.....0.00 Ω ÷ 20.0 Ω

*See chapter 5.6.2 *Voltage drop* for more information about calculation of voltage drop result

7.6 Voltage, frequency, and phase rotation

7.6.1 Phase rotation

Nominal system voltage range 100 V_{AC} ÷ 550 V_{AC}

Nominal frequency range..... 14 Hz ÷ 500 Hz

Result displayed 1.2.3 or 3.2.1

7.6.2 Voltage

Measuring range (V)	Resolution (V)	Accuracy
0 ÷ 550	1	±(2 % of reading + 2 digits)

Result type..... True r.m.s. (trms)

Nominal frequency range..... 0 Hz, 14 Hz ÷ 500 Hz

7.6.3 Frequency

Measuring range (Hz)	Resolution (Hz)	Accuracy
0.00 ÷ 9.99	0.01	±(0.2 % of reading + 1 digit)
10.0 ÷ 499.9	0.1	

Nominal voltage range..... 10 V ÷ 550 V

7.6.4 Online terminal voltage monitor

Measuring range (V)	Resolution (V)	Accuracy
10 ÷ 550	1	±(2 % of reading + 2 digits)

7.7 General data

Power supply voltage..... 9 V_{DC} (6×1.5 V battery or accu, size AA)

Operation..... typical 20 h

Charger socket input voltage 12 V ± 10 %

Charger socket input current 400 mA max.

Battery charging current 250 mA (internally regulated)

Overvoltage category.....	600 V CAT III / 300 V CAT IV
Plug test cable	
overvoltage category.....	300 V CAT III
Protection classification.....	double insulation
Pollution degree.....	2
Protection degree.....	IP 40
Display.....	128x64 dots matrix display with backlight
Dimensions (w × h × d).....	14 cm × 8 cm × 23 cm
Weight.....	1.0 kg, without battery cells
Reference conditions	
Reference temperature range.....	10 °C ÷ 30 °C
Reference humidity range.....	40 %RH ÷ 70 %RH
Operation conditions	
Working temperature range.....	0 °C ÷ 40 °C
Maximum relative humidity.....	95 %RH (0 °C ÷ 40 °C), non-condensing
Storage conditions	
Temperature range.....	-10 °C ÷ +70 °C
Maximum relative humidity.....	90 %RH (-10 °C ÷ +40 °C) 80 %RH (40 °C ÷ 60 °C)

The error in operating conditions could be at most the error for reference conditions (specified in the manual for each function) +1 % of measured value + 1 digit, unless otherwise specified in the manual for particular function.

A Appendix A - Fuse table

A.1 Fuse table - impedances (UK)

Fuse type B

Rated current (A)	Disconnection time [s]		Rated current (A)	Disconnection time [s]	
	0.4	5		0.4	5
	Max. loop impedance (Ω)			Max. loop impedance (Ω)	
3	12,264	12,264			
6	6,136	6,136	6	3,064	3,064
10	3,68	3,68	10	1,84	1,84
16	2,296	2,296	16	1,152	1,152
20	1,84	1,84	20	0,92	0,92
25	1,472	1,472	25	0,736	0,736
32	1,152	1,152	32	0,576	0,576
40	0,92	0,92	40	0,456	0,456
50	0,736	0,736	50	0,368	0,368
63	0,584	0,584	63	0,288	0,288
80	0,456	0,456	80	0,232	0,232
100	0,368	0,368	100	0,184	0,184
125	0,296	0,296	125	0,144	0,144

Fuse type C

Rated current (A)	Disconnection time [s]		Rated current (A)	Disconnection time [s]	
	0.4	5		0.4	5
	Max. loop impedance (Ω)			Max. loop impedance (Ω)	
6	1,536	1,536	5	8,36	13,12
10	0,92	0,92	15	2,624	4
16	0,576	0,576	20	1,36	2,24
20	0,456	0,456	30	0,92	1,472
25	0,368	0,368	45		0,768
32	0,288	0,288	60		0,56
40	0,232	0,232	80		0,4
50	0,184	0,184	100		0,288
63	0,144	0,144			
80	0,112	0,112			
100	0,088	0,088			
125	0,072	0,072			

Fuse type D

Fuse type BS 1361

Rated current (A)	Disconnection time [s]		Rated current (A)	Disconnection time [s]	
	0.4	5		0.4	5
	Max. loop impedance (Ω)			Max. loop impedance (Ω)	
6	6,816	10,8	3	13,12	18,56
10	4,088	5,936	13	1,936	3,064
16	2,16	3,344			
20	1,416	2,328			
25	1,152	1,84			
32	0,832	1,472			
40		1,08			
50		0,832			
63		0,656			
80		0,456			
100		0,336			
125		0,264			
160		0,2			
200		0,152			

Fuse type BS 88

Fuse type BS 1362

Fuse type BS 3036

All impedances are scaled with factor 0.8.

B Appendix B - Accessories for specific measurements

The table below presents standard and optional accessories required for specific measurement. The accessories marked as optional may also be standard ones in some sets. Please see attached list of standard accessories for your set or contact your distributor for further information.

Function	Suitable accessories (Optional with ordering code A....)
Insulation resistance	<input type="checkbox"/> Universal test cable
R LOW Ω resistance	<input type="checkbox"/> Universal test cable <input type="checkbox"/> Probe test lead 4m (A 1012)
	<input type="checkbox"/>
Voltage, frequency	<input type="checkbox"/> Universal test cable
Line impedance	<input type="checkbox"/> Universal test cable <input type="checkbox"/> Mains measuring cable <input type="checkbox"/> Three-phase adapter (A 1111)
Fault loop impedance	<input type="checkbox"/> Universal test cable <input type="checkbox"/> Mains measuring cable <input type="checkbox"/> Three-phase adapter (A 1111)
RCD testing	<input type="checkbox"/> Universal test cable <input type="checkbox"/> Mains measuring cable <input type="checkbox"/> Three-phase adapter (A 1111)
Phase sequence	<input type="checkbox"/> Universal test cable <input type="checkbox"/> Three-phase cable (A 1110) <input type="checkbox"/> Three-phase adapter (A 1111)
Voltage, frequency	<input type="checkbox"/> Universal test cable <input type="checkbox"/> Mains measuring cable