

ELCOMPONENT

Making sense of your energy



SP Max

Energy Profile Logger

SP Max™ User's Guide

Copyright © 1999 Elcomponent Ltd

All Rights Reserved.

The information in this document is subject to change without notice.

Elcomponent Ltd has made every effort to ensure the accuracy of this manual. However, Elcomponent Ltd makes no warranties with respect to this documentation and disclaims any implied warranties of merchantability and fitness for a particular purpose. Elcomponent Ltd assumes no responsibility for any errors that may appear in this document.

Trademarks

IBM is a registered trademark of International Business Machines Corporation.

Windows, Windows 95 and Windows 98 are trademarks of Microsoft Corporation.

Lotus is a trademark of Lotus Development Corporation.

All other product names are copyright and may be trademarks and/or registered trademarks of their respective companies.

PLEASE ENSURE THE SP MAX IS CHARGED FOR A PERIOD OF 48 HOURS BEFORE BEING USED FOR THE FIRST TIME.

IT IS RECOMMENDED THAT THIS UNIT BE KEPT ON CHARGE WHILST NOT BEING USED.

Symbols:

The following symbols may be used in this manual



WARNING: Failure to follow the instructions may result in personal injury or damage to the instrument.



NOTE: Failure to follow the instructions may result in an instrument or software malfunction.

Table of Contents

Introduction to <i>SP Max</i>	5
Important Safety Information	7
The Logger - Inside Front Cover	8
Status Indicators.....	8
1 - Battery Charged Indicator	8
2 - Line Power Indicator.....	8
3 - Under Voltage/Over Voltage/Phase Error Indicator.....	9
4 - Over Current Indicator.....	9
Recording Indicator	9
Sleep Button.....	9
Reset Button.....	9
Purge Valve Knob	9
Serial Port Connection	9
The Logger - Connectors	10
Voltage	10
Current.....	10
Pulse.....	11
The Logger - Connection Information	11
<i>SP PowerPack</i> Software	15
Quick Start	15
Preparing to Log.....	15
After Your Survey.....	15
Installing <i>SP PowerPack</i> Software	16
System Requirements:.....	16
Software Installation	16
Connecting the Logger to a PC	16
Starting <i>SP PowerPack</i> Software	17
Setting Up <i>SP PowerPack</i> Software	17
Identifying the Logger and Serial Port.....	17
Synchronising Logger Time and Date with the PC	19
Changing the Default Directories	20

Setting the Logging Parameters	21
Data Storage Interval and Survey Length	21
Wraparound Mode	21
Channel Configuration	21
Storing Minimum, Maximum and Average Values	21
Specifying the Type of Current Transformer in Use	22
Specifying the Sensor Type for Pulse Meter Logging	22
Setting Current and Voltage Limits for Event Detection	22
Downloading Data	26
Calculating Power	28
Displaying Power Data	28
Viewing the Data.....	31
Selecting a Display Group	31
Viewing the Data as a Listing	32
Viewing the Data as a Graph.....	32
Displaying the Survey Summary Information	33
Zooming In and Out	34
Displaying and Printing Graphed Data	34
Selecting which data to graph	35
Changing the X Axis Time Period.....	35
Adding a Text Header and Logo to the Summary Page	36
Printing a Graph and Summary Page	37
Costing	39
Setup Costing Information	39
Displaying Costing Information.....	41
Pulse Meter Logging	41
Displaying Pulse Meter Data	41
Logger Status	42
Checking Logger Status	42
Resetting the Logger	43
Adjusting the Logger - PC Communication Speed	43

When Things Go Wrong	45
Download Problems	45
Time and Date.....	47
Printing	47
Display.....	48
Appendix A - SILPRTNR.INI File Settings	49
Customising Graph Colours	49
Other SILPRTNR.INI Items	50
Appendix B - SPPOWER.INI File Settings	51
Customising SP Power Calculations.....	51
Appendix C - Power Configurations and Calculations	52
Over/Under Current Detection in the Logger	52
Over/Under Voltage Detection in the Logger	52
Average Calculations	52
Current and Voltage Combinations for Calculating Power	53
<i>SP PowerPack</i> Power Calculations	54
Appendix D - SPMAX.INI File Settings (CT Ratios/Pulse Channel Config)	55
[Current] Group.....	55
[Voltage] Group.....	55
[Pulse] Group.....	55
Type Number	56
Name	56
Pulses Per Unit.....	56
Unit of measure	56
Unit abbreviation.....	56

Introduction to *SP Max*

The *SP Max* has been developed by Elcomponent to provide the energy manager with a safe, easy and accurate method of obtaining load profiles, consumption data and power factor profiles on both three phase and single phase systems. The unit is designed to be used in conjunction with SP PowerPack software, and includes the following features:

- True RMS measurement
- $\pm 0.25\%$ accuracy on primary parameters
- Safe voltage connection via standard wall socket
- Strong weatherproof case
- Pulse input channel for external meter verification
- 512kb memory
- Foolproof 'two button' operation

Hardware Specifications

Maximum Channels	
6	Selectable storage for each channel
Range	
Ch 1	0 - 275 VAC RMS for 50/60 Hz operation.
Ch 2	0 - 1 VAC - Current CT Input
Ch 3	0 - 1 VAC - Current CT Input
Ch 4	0 - 1 VAC - Current CT Input
Ch 5	0 - 360° Ch 1 to Ch 2 – Power Factor calculated via software.
Ch 6	Pulse input – Pulse input for dry or voltage free contacts only.
External Connections	
1 voltage/auxiliary power, 1 download, 3 current, 1 pulse	
Sensor Type	
External CTs, internal impedance network for voltage	
Sampling Rate	
0.25 second	
Data Storage Rate	
1 second to 15 minutes	Set via software
Parameters Stored	
Avg, Min/Max, or Min/Max/Avg	Set via software
Samples per Average	
4 - 3600, depending on storage rate.	Set automatically
Memory	
512K, non-volatile RAM	
Memory Treatment	
Stop when full, or wrap.	Set via software
Storage Capacity	
15 days for 6 channels, Min/Max/Avg, 1 min. storage interval	Capacity depends on number of channels used and storage mode
Status Indicators	
Line Power, Over/Under Voltage, Phase Error/Over Current/No Current, Recording, Battery Charged (inside cover)	
Power	
Line Power, Internal battery	Battery recharged via line power
Battery Life	14 days

Communications

Opto-isolated RS232, support for remote set-up

Software

SP PowerPack

Requires PC running Windows 3.1 or later and 1 free serial port

Packaging

Rugged, durable ABS.

Accuracy

± 0.25 % Range + CT error

Safety

Optically isolated download

Operating Temperature

- 20°C to 50°C

Specifications subject to change without notice.

Important Safety Information

WARNING: *SP Max* has been designed for safety in use. However, individuals using the logger must be suitably qualified and trained, and are responsible for the safe operation of the logger. Please observe the following safety precautions:

- Do not allow water seepage into the logger. The logger case is not hermetically sealed and moisture can cause a shock hazard to the operator and damage to the unit.
- Never work alone with live voltage.
- When installing the logger near live voltage, connect the unit only after the power has been turned off.
- To avoid personal injury and damage to the logger, never exceed the maximum rated input voltage for a channel.

The Logger - Inside Front Cover

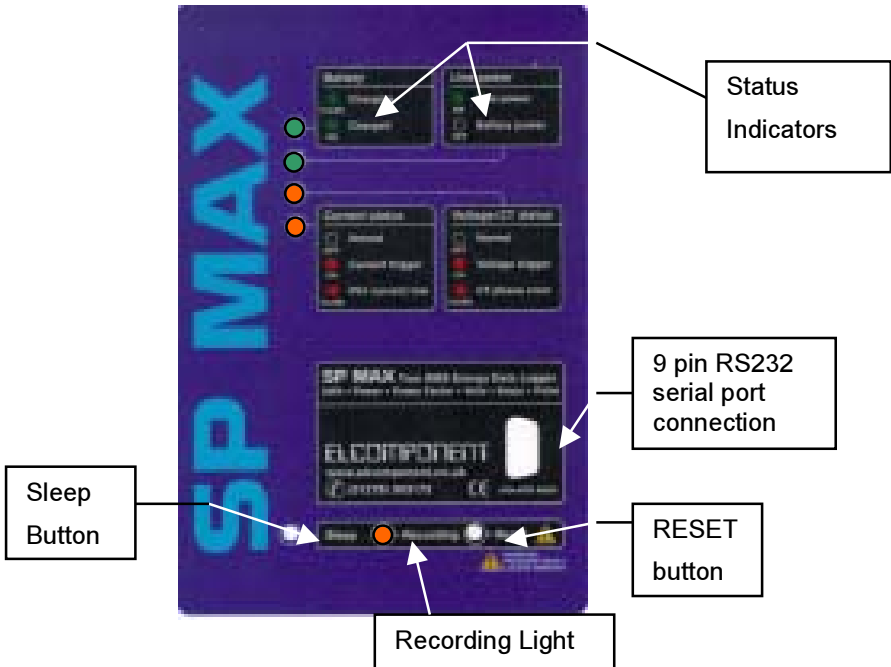

Status Indicators

There are 5 status indicators on the front of the unit. These lights may be on, off or flashing to indicate different conditions.

1 - Battery Charged Indicator

This indicator is live only when mains power is connected.

ON = Fully Charged

OFF = Discharged

FLASHING = Charging



NOTE: Under certain charge conditions the led may flash in an irregular fashion. This does not indicate a malfunction.

2 - Line Power Indicator

When the Line Power light is ON it indicates that the logger is operating on line power. The light is OFF when the logger is operating on battery power.

3 - Under Voltage/Over Voltage/Phase Error Indicator

Using **SP PowerPack**, you can set voltage alarm levels in the logger. If **SP Max** detects a voltage outside this range at any time during a survey, the Under Voltage/ Over Voltage light is turned ON. The light FLASHES to indicate that the voltage and Channel 1 current are out of phase (see page 8). Resetting the logger clears the memory and turns off the Under Voltage/ Over Voltage light.

4 - Over Current Indicator

Using **SP PowerPack**, you can set an overcurrent alarm level range in the logger. If **SP Max** detects a current above this range at any time during a survey, the Over Current light is turned ON. The light FLASHES to indicate that the current has fallen below the specified range and that the power factor calculation has been discontinued. If the light is OFF, no over or under current event has been detected. Resetting the logger clears the memory and turns off the Over Current light.

Recording Indicator

The Recording light blinks while **SP Max** is logging.

Sleep Button

The Sleep button is a recessed control. Press the Sleep button before disconnecting or transporting **SP Max** to stop the logging function and power down the logger to standby mode. This minimises the risk of data loss and prevents the logger from recording zero values after it has been disconnected.

Reset Button

The RESET button is a recessed control. Press RESET after transporting the logger to the survey site and connecting it. Resetting clears the logger's memory, clears the Under Voltage/Over Voltage and Over Current event detection lights, and begins a new survey.



NOTE: Because resetting clears the logger's memory, make sure to download any logged data before pressing RESET. To carry out a reset, the button must be depressed for at least 3 seconds.

Purge Valve Knob

The **SP Max** case includes a purge valve, however it is not functional. The logger cannot be hermetically sealed. To avoid a shock hazard to the operator and damage to the unit do not allow water seepage into the logger.

Serial Port Connection

The communication cable supplied with **SP Max** connects at this 9 pin RS232 connector.

NOTE: Be sure to use the cable supplied with the logger when connecting to a PC

The Logger - Connectors

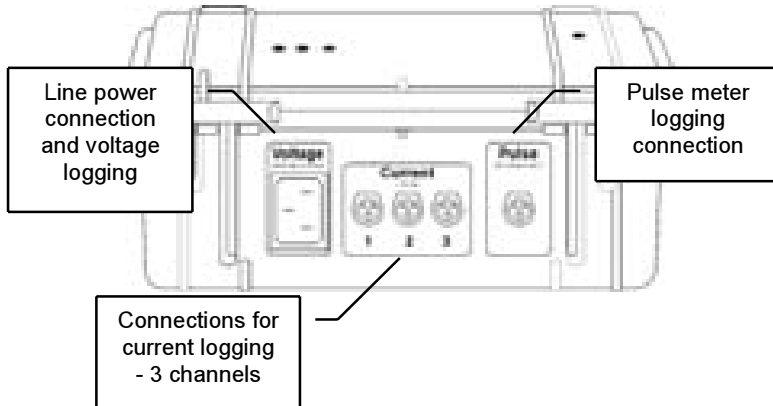

The connections to the logger are located on the side of the unit.

Voltage

The voltage input connector is a standard IEE type and is normally connected to a standard 230V wall socket with the cable supplied. A 'croc clip' accessory cable is also available.



WARNING: If the 'croc clip' is used the connected voltage must not exceed 250VAC. On three phase systems the connection must be made between phase and neutral. Connecting the voltage input phase to phase will damage the logger and could be hazardous.

Current

The three current input connectors are for Current Transformer (CT) connection only, and are normally used with the CTs provided in the SP MAX kit. Other suitable CTs are available as accessories



WARNING: The inputs are designed for connection to CTs with a maximum output of 1VAC. Connection to other types of CT will damage the logger and could be hazardous.

Three inputs are provided, and may be used either as the three phases of a three phase system, or as separate channels of multiple single phase loads.

Pulse

The pulse input connection is designed for connection to an external volt-free contact. The necessary power for the current loop is provided by the logger.

WARNING: Do not connect the pulse input to a power supply. This will damage the logger and could be hazardous.



A pulse input cable is supplied in the standard **SP Max** kit.

The Logger - Connection Information

The **SP Max** has been designed to make connection as quick, easy and safe as it can be.

It's QUICK because there is a minimum number of connections to make.

It's EASY because the led indicators clearly show a 'go/no go' situation.

It's SAFE because the only connection required is made to a standard 13A wall socket, avoiding the need for live conductors to be exposed.



NOTE: Before connecting the SP Max to a supply please read the instructions relating to the SP PowerPack software and instrument set up.

Once you have programmed the logger for your desired survey, connecting it to the supply is carried out as follows:

SINGLE PHASE

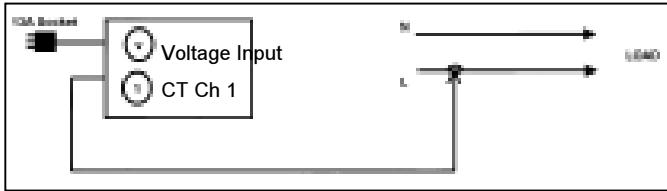

Connection using Wall Socket

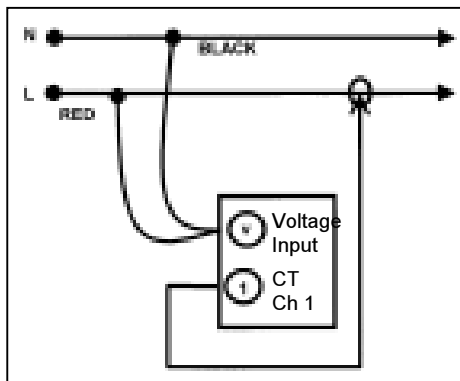

Connection using 'Croc Clip' Voltage Lead

1. Press and hold reset button to enable the Logger.

NOTE: This will clear any data in the memory.

2. Connect the mains cable to a convenient wall socket, or connect the croc clip/lead as shown in the above diagram.
3. Connect a CT to Channel 1 input. Place the CT around the LIVE cable of the load to be monitored. Ensure that the arrow on the CT is pointing towards the load.
4. Check that led 2(green) is on to indicate live voltage is present, and that led 3 (red) is off indicating the CT orientation is correct. If led 3 is flashing, simply reverse the direction of the CT on the cable.



NOTE: if led 4 (red) is flashing, it is not possible for the instrument to detect the CT orientation. Ensure that the minimum current trigger is set at a level below the level of current actually flowing (see page 8)



NOTE: If leds 3&4 are permanently on, a trigger condition has been detected, but this does not affect the operation of the data logging.

THREE PHASE

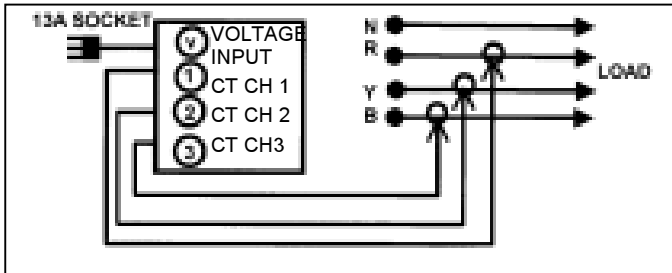

Connection using wall socket

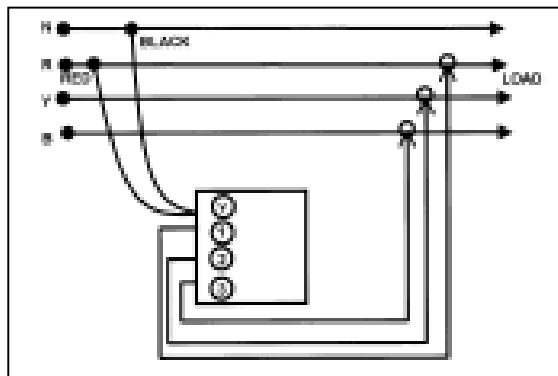

Connection using 'croc clip' voltage lead



WARNING: do not connect voltage input phase to phase

1. Press and hold reset button to enable the Logger.



NOTE: This will clear any data in the memory

2. Connect the mains cable to a convenient wall socket, or connect the croc clip as shown in the above diagram.
3. Connect a CT to channel 1 input. Place the CT around the red phase conductor ensuring that the arrow is facing towards the load.
4. Check that led 2 (green) is on to indicate live voltage is present, and that led 3 (red) is off indicating the CT orientation is correct. If led 3 is flashing, remove the CT from the red phase and place it on yellow (maintaining the same orientation of the arrow). Repeat this procedure with the blue phase if the led continues to flash. If the led continues to flash on all phases, the orientation of the CT is incorrect. Reverse the direction of the arrow and repeat the above procedure until the led goes out.



NOTE: if led 4 (red) is flashing, it is not possible for the instrument to detect the CT orientation. Ensure that the minimum current trigger is set at a level below the level of current actually flowing (see page 8)



NOTE: If leds 3&4 are permanently on, a trigger condition has been detected, but this does not affect the generation of the data logging.

Once the first CT has been correctly connected, the remaining two CTs can be hooked up. The position and orientation of these is not significant.

When the **SP Max** has been correctly connected to the supply to be monitored, it is recommended that the instrument is reset, to clear the memory and restart data logging. At this point it is useful to check the led status (see page 4-5) to ensure the unit is working correctly.

Introduction to SP PowerPack Software

The **Silent Partner PowerPack** software (**SP PowerPack**) is supplied in the standard **SP Max** kit, and is an essential part of the package. It is used to:

- Set up the logger
- Set the logging parameters
- Interrogate the logger (status report)
- Download collected data
- Display, manage and print downloaded data.

- Calculate energy consumption and power data from primary measured values.

***SP PowerPack* Software**

SP PowerPack is a Windows-based application so you will find the interface familiar. It employs the same menu structure and screen navigation as other Windows programs. Simply make selections using a mouse, or from the keyboard by pressing the underlined letter of the command you wish to select. Dimmed menu items are unavailable.

For additional information on using Windows refer to your Windows documentation or on-line Help.

Quick Start

This section provides an overview to help you get started quickly. Please read through the remainder of this manual for important information on the correct set-up and use of the ***SP Max*** logger and ***SP PowerPack*** software.

Preparing to Log

1. Install ***SP PowerPack*** software.
2. Start ***SP PowerPack*** software.
3. Connect the ***SP Max*** logger at the PC serial port.
4. Select the logger type and serial port, set the time and date, and specify the data logging parameters.
(**Set-up, Logger Serial Port), (**Logger, Set Time and Date**)
(**Logger, Change Parameters**)**
5. Disconnect the logger from the PC.
6. Connect the logger to the load you wish to monitor.
7. **RESET** the logger to begin your survey.

After Your Survey

1. Disconnect the logger from the load and connect it to the PC.
2. Start ***SP PowerPack*** and download the data.
(**Logger, Download SP Data**)
3. Set-up the Power, Costing or Pulse calculations.
(**Set-up, Range/Power**), (**Set-up, Range/Power**),
(**Set-up, Pulse Rate Period**)

4. Select a display group.
(**S**et-up, **M**easurement Scale)
5. Select a report type.
(**V**iew, *report type*)
6. Tailor the report's appearance to suit your needs.
(**S**et-up, **D**isplay/Print Options)
7. Print the report and save the file.

Installing SP PowerPack Software

System Requirements:

- 486 or better (Pentium recommended)
- Windows 98 or later
- VGA display
- COM1, 2, 3, or 4 (serial communications port)
- Hard disk with 1 megabyte free
- CD ROM Drive (for program installation)

Software Installation

1. Make sure that your computer is running Windows 98 or later.
2. Insert the **SP** disk in the CD ROM Drive.
3. Click  and select **R**un to open the Run dialog box.
4. In the Run dialog box, type **D:\SETUP**.
5. Follow the on-screen instructions.

A program group named **SP** and a **SP PowerPack** icon are created during installation. To run the program, double click the icon.

After installing the software you will need to specify the type of logger you are using and the number of the serial port that you will use to communicate with the logger. In addition, you may wish to change the default directories in which **SP** stores data and export files. Turn to **Setting Up SP PowerPack Software** for instructions.

Connecting the Logger to a PC

1. Attach the power cord at the socket on the side of the logger.



NOTE: Not necessary if the battery is fully charged.

2. Plug the power cord into an electrical outlet. The Line Power light will come on.
3. Open the logger's front cover and plug the download cable into the 9 pin connector.
4. Plug the other end of the download cable into a serial communication port on the back of the PC.

The first time you communicate with a logger from a PC you will need to identify for the software which logger type and COM port you are using.

Starting SP PowerPack Software

1. Double click the **SP** icon to start the program and display the opening screen.



After a few seconds the opening screen closes to display a blank screen with the **SP PowerPack** title bar and main menu at the top.

Setting Up SP PowerPack Software

After installing **SP PowerPack**, you must complete the set-up of the software. Elcomponent Ltd offers a broad range of Silent Partner loggers, all supported by **SP PowerPack**. The first time you communicate with your logger from a PC you will need to identify for the software which model of logger you are using. You will also need to specify which PC serial port will be used to communicate with the logger, and synchronise the logger's time and date with that of the PC. You may also wish to change the default directories that **SP PowerPack** uses to store data files and export files.

Identifying the Logger and Serial Port

1. Click **Logger Serial Port** in the **Set-up** menu to open the Logger Port Set-up dialog box.
2. Scroll down the **Select Logger Type** list and click **SP Max**.

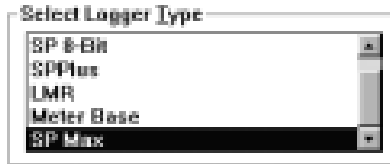

3. In the **Select Serial Port for Logger** list, click the **COM** port to which the logger is attached.

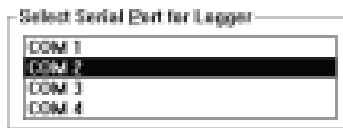

If you do not know the COM port's number you can instruct **SP** to scan all the ports and locate the logger. To scan ports for the logger, proceed to **Step 4**. If you have already selected the COM port, go to **Step 7**.

4. Click **Start Port Scan for Logger**. **SP PowerPack** reminds you to connect the logger.



5. Click **OK**. **SP** confirms the location of the logger.



- Click **OK**. **SP** selects the port at which the logger was found as the download port.

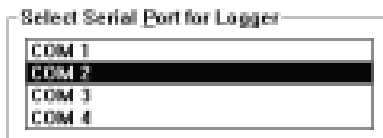

- Click **OK** again to confirm the selection and close the Logger Port Set-up dialog box.

Synchronising Logger Time and Date with the PC

To ensure the accuracy of your surveys you will need to synchronise **SP Max**'s internal clock with that of your PC before logging any data. You may also need to re-synchronise the clock if you use **SP Max** with a different PC, or after you have recharged the logger's battery.

 **NOTE: Changing the time and date erases the logger's memory and resets the logger. Download any data before synchronising.**

 **NOTE: The accuracy of your data in respect of logging timer is only as good as the PC used to set up the *SP Max*. If your PC clock wrongly set, all collected data will also be misreported in this respect.**

- Make sure the logger is connected to the correct PC serial port.
- Click **Set Time and Date** in the **Logger** menu. **SP PowerPack** communicates with the logger and displays a warning. If you have logged data that you wish to save, click **Cancel** and turn to **Downloading Data**. Otherwise, proceed.



- Click **OK**. **SP PowerPack** synchronises the time and date in the logger with the time and date in the PC and displays a confirmation message.



- Click **OK** to close the Logger Clock Time confirmation message.



NOTE: *SP PowerPack* lets you synchronise the time and date. However the format in which time and date appear is determined by the selection you make in the **International Settings** section of your **Windows Control Panel**. For information on **Windows** time and date formats refer to your **Windows** documentation or on-line Help.

Changing the Default Directories

At installation, **SP** creates two subdirectories or folders in which it stores data files. Files downloaded from the logger are stored in C:\SP\DATA. Data files you export in Lotus.WK1 format are stored in C:\SP\EXPORT. **SP** allows you to change one or both of these default directories.

1. Click **D**irectories in the **S**et-up menu. **SP** displays the Data File Directory Selection dialog box.

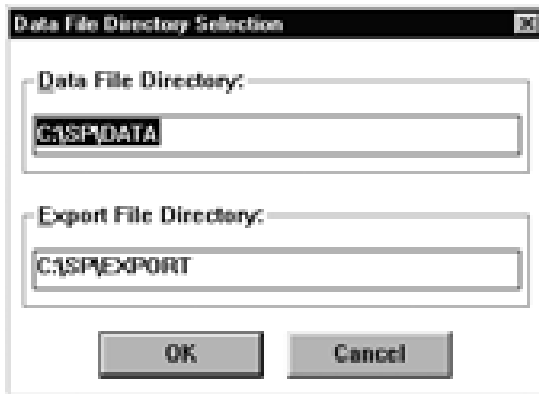

2. To change the directory in which data files are stored, type the new path in the **D**ata File Directory text box. To change the directory in which export files are stored, type the new path in the **E**xport File Directory text box.
3. Click **OK** to confirm the change and close the Data File Directory Selection dialog box.

Setting the Logging Parameters



NOTE: Changing the parameters erases the logger's memory and starts a new survey. Download any data before changing parameters.

Data Storage Interval and Survey Length

SP Max has the flexibility to store sampled data at intervals from 1 second to 15 minutes. Because a shorter data storage interval results in the logger's memory becoming full more quickly, you can choose to store values frequently over a relatively short period or less frequently over a longer survey. Alternatively, you may wish to log data over a specified period of time. *SP PowerPack* lets you select a survey duration of between 5.4 hours and 202.1 days depending on channel set-up and the logger automatically adjusts its data storage interval to accommodate the survey length you choose.

Wraparound Mode

SP Max has 512 kb of non-volatile RAM. You can instruct the logger to respond in one of the following two ways when its memory is full:

- stop recording and enter Sleep mode to conserve energy, or
- continue recording and 'wrap around' to replace the oldest data with new data.

Channel Configuration

SP Max has 6 data input channels; 1 voltage channel, 3 current channels 1 pulse channel and 1 computed power factor channel. You can log data on all 6 channels simultaneously or disable some channels. When a channel is disabled, the memory allocated to it is reassigned to the active channel or channels, allowing you to record longer surveys. Voltage is logged via the unit's line power input. For current logging you must identify for the software the type of clamp you are using. For pulse meter logging you need to identify the type of sensor. You will also need to set current and voltage limits for out-of-range event detection. In addition, you can select whether the logger stores the minimum and maximum values recorded during a storage interval, the average of all values recorded, or both.

Storing Minimum, Maximum and Average Values

SP Max samples data multiple times during each storage interval. You can specify whether the logger stores the lowest and the highest readings collected during the storage interval (Min/Max), an average of all readings collected during the interval, or both.

 **NOTE:** The SP MAX must be set up to include average values if power and energy calculation is required. I.e. to obtain kVA, kW or kWh values ensure that the ‘average’ box is checked in the ‘Change Parameters’ window.

Specifying the Type of Current Transformer in Use

Before logging current you will need to specify for the software which type of clamp you are using. You do this by selecting the range for which the clamp is rated. The default value is 1000A, which is correct for the CTs supplied in the standard kit.

Specifying the Sensor Type for Pulse Meter Logging

Before beginning a pulse meter survey you will need to specify for the software the type of sensor you are using. You do this by selecting an option from the list. For instructions on adding different types of pulse meters to the list, refer to **Appendix D**.

1. To specify the type of pulse sensor in use, click the **Sensor** button to open the Sensor Type Selection dialog box..

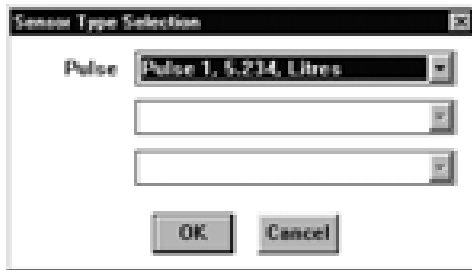

2. Open the **Pulse** drop-down list and select the appropriate sensor type. Then click **OK**.

Setting Current and Voltage Limits for Event Detection

Indicators on the front of the logger indicate if current or voltage outside a specified range has been detected during a survey. This event detection flags the need for further analysis of the logged data. **SP Max** allows you to specify the anticipated range for both current and voltage. If **SP Max** detects any readings outside this specified range, the appropriate led is activated.

1. Click **Change Parameters** in the **Logger** menu. **SP PowerPack** communicates with the logger and displays the Change Logger Parameters dialog box.

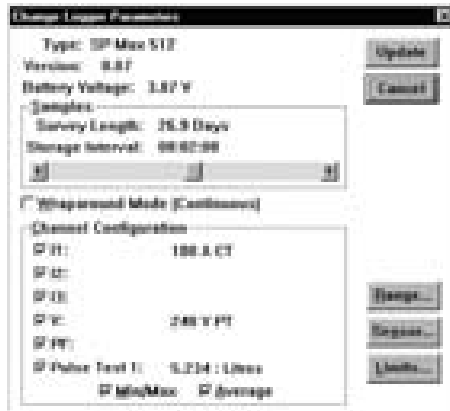

2. To adjust the Survey Length and Storage Interval move the **slider**.



3. To instruct the logger to replace the oldest data with new data, select **Wraparound Mode (Continuous)**.

Wraparound Mode (Continuous)

To instruct the logger to stop recording and enter Sleep mode when its memory is full, deselect **Wraparound Mode**.

4. To enable data logging on any channel, select it.
To disable a channel, deselect it.

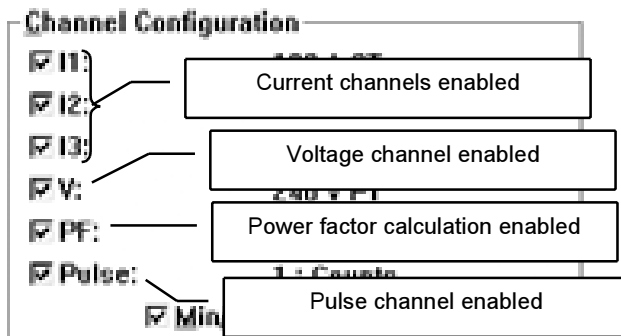



 **NOTE: Pulse logging is disabled if the *SP Max* is running on battery power. Ensure a mains cable is connected if pulse logging is required.**

5. To enable storage of the lowest and highest recorded values select **Min/Max**.

To enable storage of the average value select **Average**.

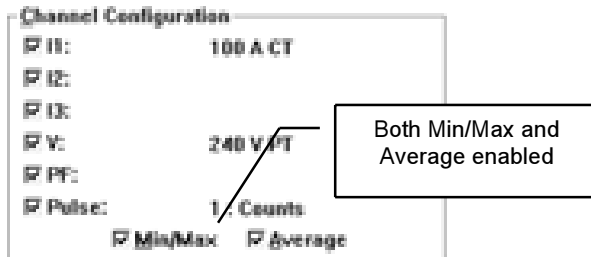
To disable the storage of either measurement, deselect that measurement.



 **NOTE: If the *SP Max* is being used to measure power or energy (eg kW, kWh etc). It is essential to check all boxes except 'Pulse'. Power and Energy cannot be calculated unless at least one current (I) the Voltage (V) and the 'Average' boxes are checked.**

6. To specify the type of current transformer in use, click the **Range** button to open the CT Ratio Selection dialog box.

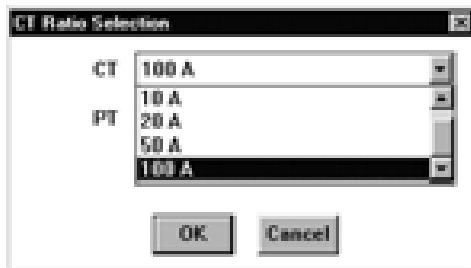

7. Open the **CT** drop-down list and select the appropriate CT value. Then click **OK**.

 **NOTE: *SP Max* logs voltage through the unit's power cable and the voltage range cannot be changed.**

- To set the anticipated current and/or voltage range, click the **Limits** button to open the Over/Under Parameters - Logger dialog box.

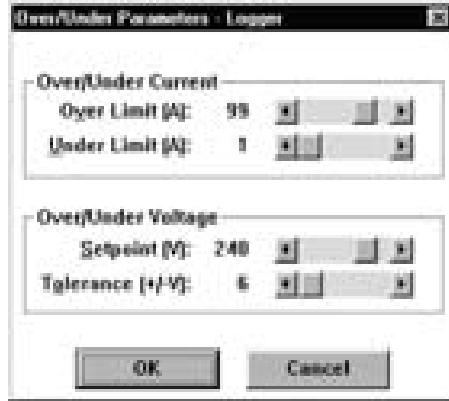

- Move the **sliders** to adjust the upper and lower limits for current or the setpoint and tolerance for voltage. Then click **OK**.
- Click **Update**. **SP** displays a warning that changing logging parameters erases the logger's memory. If you have logged data that you wish to save, click **Cancel** and turn to **Downloading Data**. Otherwise, proceed.



 **NOTE: Do not set the Under Current limit to zero. This will disable the unit's ability to detect CT orientation and phase position.**

- Click **OK**. **SP PowerPack** communicates with the logger, updates the parameters and displays a confirmation message.

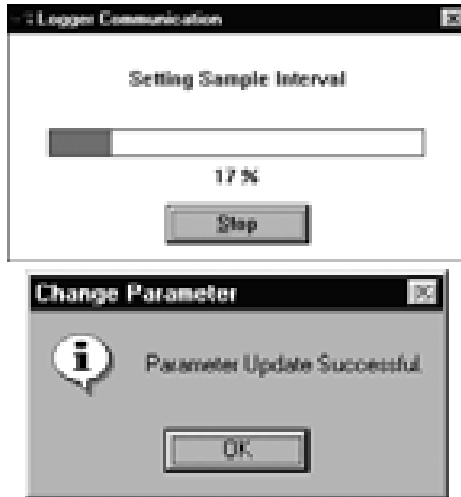

12. Click **OK**.

Downloading Data

Once your survey is finished, you will need to download the data from the logger to your PC. Note that downloading does not clear the data from the logger. You can download the same data again, provided that you have not cleared the logger's memory by resetting, changing the logging parameters or using the Set Time and Date function.

1. Open the logger's front cover. Plug the download cable into the 9 pin connector on the logger. Plug the other end of the cable into the correct COM port on the back of the PC.
2. Click **D**ownload **SP** Data in the **L**ogger menu. **SP PowerPack** displays a progress bar while it downloads the data and a confirmation message when the download is complete.
3. Click **OK**. **SP** displays the Ratio/Power Selection dialog box to allow you to change the current range scaling for each channel or to set-up the power calculation. You can make your selections now, or return to the Ratio/Power Selection dialog box after the file has been saved.
4. Click **OK**. **SP PowerPack** displays the Survey File Summary dialog box. This dialog box allows you to name the survey, add descriptive notes, view the minimum and maximum reading for the survey period, or open the Range/Power Selection dialog box.

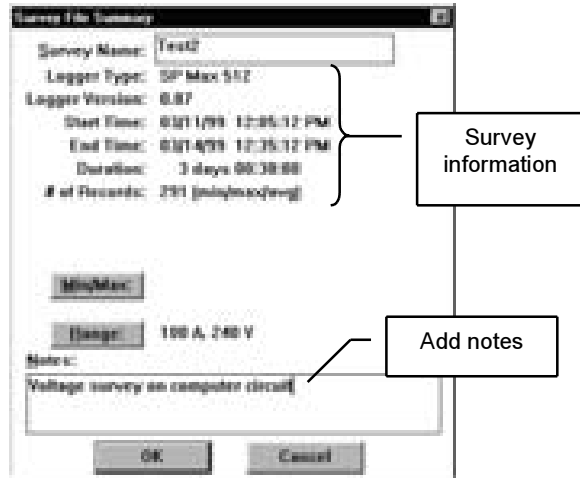

5. To name the survey, click in the **Survey Name** text box and type in a file name.
6. To add comments or a description, click in the **Notes** text box and type your comments. This information will appear on the Report Summary printout.
7. To view minimum and maximum readings during the survey period, click the **Min/Max** button. **SP PowerPack** opens the Data Min/Max Values dialog box to display the minimum and maximum values for the selected display group.
8. Click **OK** to close the Data Min/Max Values dialog box.
9. Click **OK** on the Survey File Summary dialog box. **SP PowerPack** opens the Windows **Save As** dialog box.



10. Click in the **File name** text box and name the file.

File names may be no more than 8 characters long and cannot include spaces. You may use any letter or number or any of the following characters in file names: underscore (_), caret (^), dollar sign (\$), tilde (~), exclamation point (!), number sign (#), percent sign (%), ampersand (&), hyphen (-), braces {}, parentheses(), at sign (@), apostrophe (') or the grave accent (`).

11. Click **OK** to close the dialog box and save the file.

Calculating Power

When the Power Factor, Voltage and first Current channels are enabled, **SP Max** logs the phase angle between the Voltage and the Channel 1 current. **SP PowerPack** can use this data to develop the Power Factor and calculate kW and kWh values.

Alternatively, you can choose to log only Current or Current and Voltage and then specify a Power Factor in the software. In this case, **SP PowerPack** uses the logged data and the specified Power Factor to calculate kW and kWh values.

It is important to set up the logger correctly to generate reliable power data. After completing the survey and downloading the data, you will need to specify the Power Set-up using the Ratio/Power Selection dialog box.

Displaying Power Data

1. Download the data and save the file.
2. Click **Range/Power** in the **Set-up** menu to open the Ratio/Power Selection dialog box.

The screenshot shows a dialog box titled "Ratio/Power Selection". It contains several sections with dropdown menus and buttons. The "Channel Data" section has "CT" set to "100 A" and "PT" set to "240 V". The "Power Setup" section has "Supply Type" set to "None", "Load Type (PT)" set to "Logger PT Data", and "Logger PT Data" set to "None". The "Voltage" section has "Source" set to "Fixed", "Value" set to "240", and "PT Ratio" set to "None". The "Current" section has "Source" set to "None", "Range" set to "100 A", and "External CT" set to "None". There are "OK" and "Cancel" buttons on the right side of the dialog.

3. If you need to change the current clamp specified, open the **CT** drop-down list in the Channel Ratio pane and select the range.
4. Open the **Supply Type** drop-down list in the Power Set-up pane.

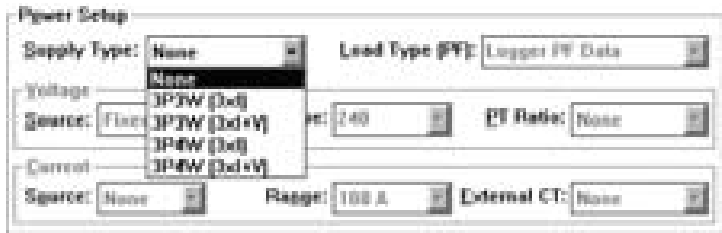

NOTE: Single phase (1P2W) will only appear as an option if the survey was carried out with one current channel enabled. Options vary according to the set up used for the actual data logging itself.

5. Select the type of power distribution system logged during the survey from the **Supply Type** drop-down list. Supply type menu structure is as follows:

1P2W (1 x I) = Single phase current only logged

1P2W (1 x I + V) = Single phase current and voltage logged

3P3W (3 x I) = 3 phase current only logged on delta system

3P3W (3 x I + V) = 3 phase current and voltage logged on delta system

3P4W (3 x I) = 3 phase current only logged on star system

3P4W (3 x I + V) = 3 phase current and voltage logged on star system

It is possible that other combinations may be available depending on the logger set up at the time the survey was carried out.

Supply Type: 3P4W (3xI+V)

A 3 Phase, 4 wire system; power calculated using 3 measured currents and measured voltage.

- If you logged the Power Factor, select **Logger PF Data** in the Load Type drop-down list. If Power Factor was not logged, select the correct option, or enter a known PF value.

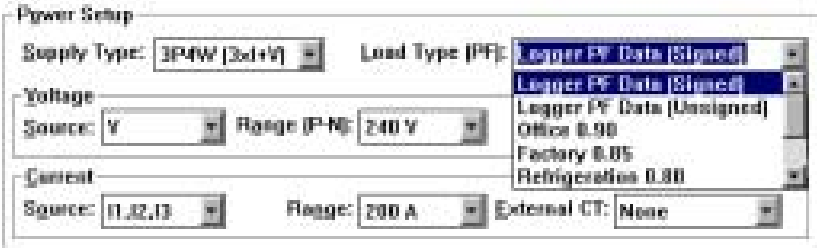

- If voltage was not logged, the **S**ource window in the voltage box will show 'Fixed'. A value must therefore be entered into the **R**ange window. For UK systems a P-N (phase to neutral) value of 240V or a P-P value of 415V should be selected. Any desired value can be entered, and is used by the software to calculate derived power and energy readings in the absence of any measured voltage data. If voltage was logged, the Source window will show 'V' indicating the measured values of voltage are available. In this instance the value showing in the **R**ange window has no effect.
- If you did not log Voltage, but selected a fixed Voltage Value and wish to apply a multiplier to the data, open the **P**T Ratio drop-down list in the Voltage pane and select a factor.
- If you wish to apply a multiplier to the Current data, open the **E**xternal CT drop-down list in the Current pane and select a factor.
- Click **OK** to close the Ratio/Power Selection dialog box.
- Click **Measurement Scale** in the **S**et-up menu to open the Measurement Scale Selection dialog box.

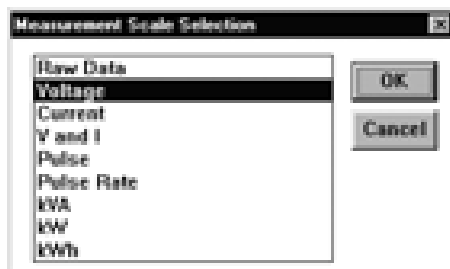

12. Select **kVA**, **kW** or **kWh** to display the power data. Note that total kWh data is displayed as 30 minute bar graphs rather than line graphs.



NOTE: Unless the relevant data has been entered into the power selection set-up window, the Measurement Scale Selection options will be limited to Raw Data and Primary Parameters only.

For details on **SP PowerPack's** power calculations, refer to **Appendix C**. Note that after the power data has been calculated, you can enable **SP PowerPack's** Costing feature.

Viewing the Data

SP PowerPack allows you to view logged data in a variety of different ways. You can select which channel or channels you would like to display. You can view the data as a graph or in tabular form. You can display summary information about the survey, and you can zoom in for a more detailed view of the data relative to the graph's Y axis.

Selecting a Display Group

SP Max can log minimum, maximum and average readings on 6 separate input channels. To display this volume of data most clearly, **SP PowerPack** organises it into subsets. The software allows you to select a display group which is defined as a single channel or a group of related channels. The display group you select automatically sets the following display parameters:

- which data appears in graphs
- which units of measurement appear on graphs
- which data appears in tabular data lists
- which units of measurement appear in the Logger Status dialog box
- which minimum and maximum data values appear in the Data Min/Max Values dialog box
- which trace selections appear in the Display/Print Options dialog box.

Where possible, the last selected display group becomes the default when you open or download a new file. If **SP PowerPack** does not display you data or does not display the channel you wish to see, you may need to select a different display group.

1. Click **Measurement Scale** in the **Set-up** menu to open the Measurement Scale Selection dialog box. Note that kVA, kW and kWh appear in the list only after you specify a Supply Type in the Ratio/Power Selection dialog box.



2. Select a display group to specify the information you would like to display.
3. Click **OK** to close the Measurement Scale Selection dialog box.

Viewing the Data as a Listing

1. Click **Measurement List** in the **View** menu. **SP** displays the data in tabular form. Depending upon the display group you have selected, the table will include different information, however the item number, date and time of each sample is always shown.

II: Current (A), V: Voltage (V), PF: PF (PF), Pulse 1: Pulse 1 (UR)

Item	Date	Time	V Volts		
			Min	Max	Avg
1	03/17/99	11:13:05 AM	256.3	256.3	256.3
2	03/17/99	11:13:06 AM	256.0	256.4	256.3
3	03/17/99	11:13:07 AM	255.6	256.4	255.9
4	03/17/99	11:13:08 AM	256.3	256.4	256.3
5	03/17/99	11:13:09 AM	256.3	256.4	256.3
6	03/17/99	11:13:10 AM	256.3	256.5	256.4

Viewing the Data as a Graph

1. Click **Measurement Graph** in the **View** menu. **SP** displays the data as a graph. Depending upon the display group you group you have selected, the graph will include different information and display different units of measurement.

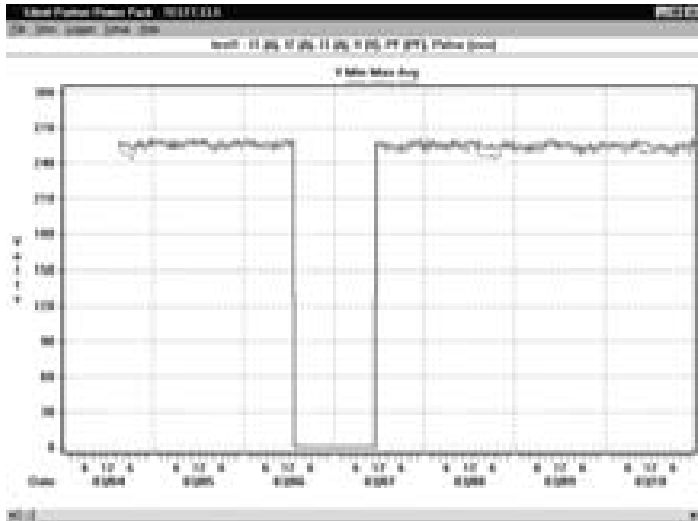

Displaying the Survey Summary Information

You can check the summary information for any survey quickly and easily.

1. Click **Survey Summary** on the **View** menu OR click **Survey Description** in the **Set-up** menu. **SP PowerPack** displays the Survey File Summary dialog box.

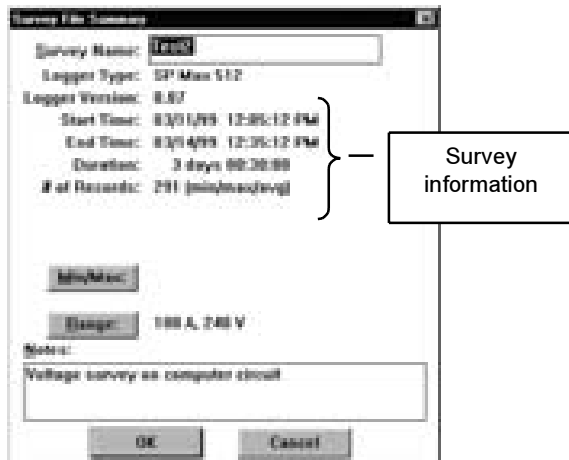

2. To display the minimum and maximum readings during the survey period for the display group you have selected, click the **Min/Max:** button.

The minimum and maximum values are displayed in the format shown below. To close the Data Min/Max Values dialog box, click **OK**.

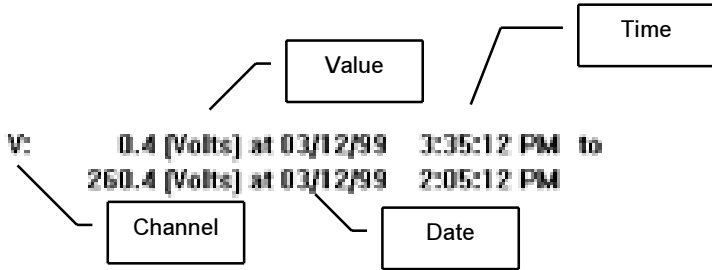

3. To examine the current range scaling for each channel or set-up the power calculation, click the **Range:** button. To close the Ratio/Power Selection dialog box, click **OK**.
4. Click **OK** to close the Survey File Summary dialog box.

Zooming In and Out

SP PowerPack allows you to zoom in on a graph for a more detailed view of the data relative to the Y axis. The software automatically selects the closest zoom that still allows the minimum and maximum graphed values to be displayed. Then you can zoom out to return to the overview.

1. Click **Z**oom on the **V**iew menu. **SP PowerPack** displays a magnified view of the graphed data.
2. Click **U**nzoom on the **V**iew menu. **SP PowerPack** displays the overview of the graphed data.

Displaying and Printing Graphed Data

SP PowerPack gives you control over how your data is displayed, graphed and printed. You can choose which traces, channel or channels to include in a graph, select the length of time displayed or printed on a graph, and add a title, other text or your company logo to the summary page of all your printed reports.

Selecting Which Data to Graph

Although **SP Max** can log minimum, maximum and average data on all 6 channels simultaneously, you may prefer not to display or print all logged traces. **SP PowerPack** lets you choose to display or print a single trace or a combination of traces.

Changing the X Axis Time Period

SP PowerPack allows you to select the period of time included on a single displayed or printed graph. You change the time period by adjusting the graph's X axis.

1. Click **Display/Print Options** in the **Set-up** menu to open the Display/Print Options dialog box. The channels displayed in the Trace Selections pane change depending upon which display group you have selected.

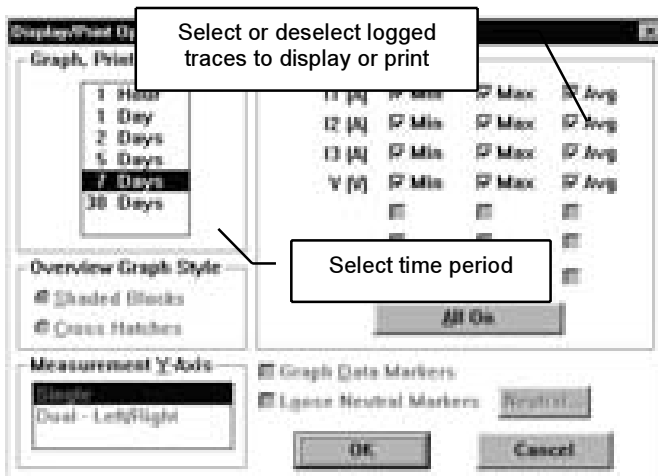

2. To display or print a specific trace, select it.
To prevent a trace from displaying or printing, deselect it.
To display or print all logged traces, click the **All On** button.
3. Click to select an alternate time period in the Graph, Print List Length pane. The selection you make here also determines the minimum time period that can be printed in a graph or list.

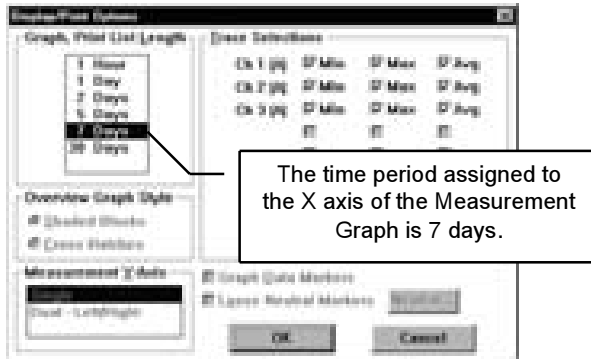

4. Click **OK** to close the Display/Print Options dialog box.

Adding a Text Header and Logo to the Summary Page

SP PowerPack allows you to add a title, slogan or other text as a header on the Summary Page of all your graphs and reports. You can include a bitmap of your company logo so that it prints as well on the Summary Page.

1. Click **Header** in the **Set-up** menu to open the Header Set-up dialog box.

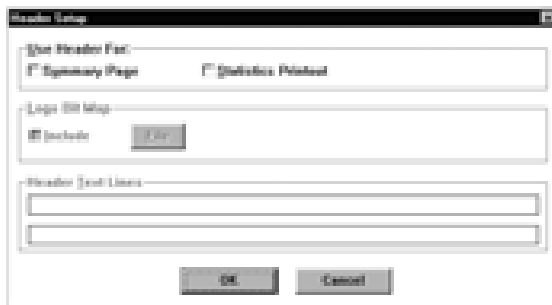

2. Select **Summary Page** in the Use Header For pane. Note that the Statistics Printout feature is unavailable for **SP Max**.
3. Click to place the insertion point in the upper text box labelled **Header Text Lines**. Note that there are 2 text boxes, allowing for 2 lines of text in the header.

4. Type in the text. If you wish to add a second line of header text, press **Tab** OR click to place the insertion point in the lower text box and then type in the text.

Header Text Lines

prepared for you by

ABC Energy Consulting Ltd.

5. Select **Include** in the Logo Bit Map pane.
6. Click **File** in the Logo Bit Map pane to open the Select Summary Logo Bitmap File dialog box and specify the location of the bitmap. You will find a sample file named **Elc.bmp** in the **spk** directory or folder.



7. Select the bitmap you would like to include. If you do not have a bitmap of your logo, but would like to test this feature, you can use the sample Elcomponent log, **Elc.bmp**.
8. Click **OK**. **SP PowerPack** displays the location of the logo bitmap beside the File button in the Header Set-up dialog box.

Logo Bit Map

Include C:\SP\LOGO.BMP

9. Click **OK** to close the Header Set-up dialog box.

Printing a Graph and Summary Page

With **SP PowerPack** you can choose to print all the data for a survey or only those readings that occurred during a specific time period. You can enable or disable printing of the Summary Page or specify the print quality of the graph or listing. You can also open a Print Set-up dialog box to select the page orientation or access other print set-up functions.

1. Make sure that the graph or list you wish to print is open and that the data is displayed as you would like to see it printed.
2. Click **P**rint in the **F**ile menu to open **SP PowerPack's** Print dialog box.

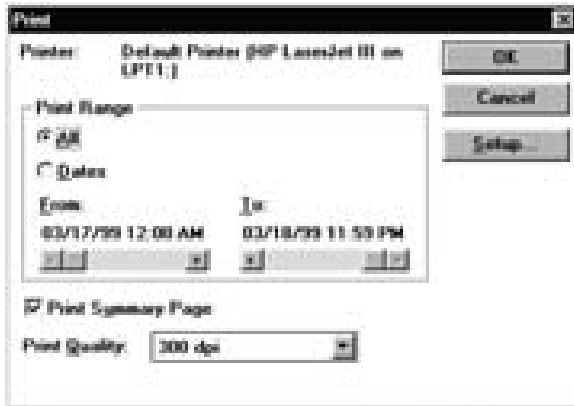

3. To print all the data for a survey, select **All** in the Print Range pane.
To print only those readings that occurred during a specific time period, select **Dates** in the Print Range pane and then move the **sliders** to specify the time period.

The minimum Print Range you can select depends on the Graph Print List Length you selected in the Display/Print Options dialog box. For example, if you selected a Graph Print List Length of 2 days, the minimum Print Range will also be 2 days.

4. To enable printing of the Summary Page, select **P**rint **S**ummary **P**age.
To disable printing of the Summary Page, deselect **P**rint **S**ummary **P**age.
5. To change the print quality, open the **P**rint **Q**uality drop-down list and select an alternative dpi rate.
6. To change the page orientation click the **S**et-up button to open the Print Set-up dialog box and select **P**ortrait or **L**andscape.
7. Make any other changes to the Print Set-up you would like, and then click **O**K to close the Print Set-up dialog box.
8. Click **O**K on the Print dialog box to close the dialog box and print the selected information.

Costing

SP PowerPack allows you to calculate the basic cost of the energy power you use and the software supports both peak (Day Rate) and off-peak (Night Rate) rate structures. To set-up the Costing feature, simply specify the time of the peak billing period. **SP PowerPack** automatically applies the off-peak rate to the remainder of the day. Then input the cost per kWh for the peak billing period and for the off-peak period if that applies. The software stores this set-up information.

To calculate and display the cost of your power consumption, enable the feature while displaying your kWh data as a graph or list.

Set-up Costing Information

1. Click **Costing** in the **Set-up** menu to open the Costing Set-up dialog box. When costing is disabled, both panes in the dialog box are dimmed.
2. Select **Costing Enabled** to turn the feature on and to activate the Day Rate and Night Rate panes in the dialog box. If **None** has been selected as the Active Period in either pane, the Active Period in the other pane will be **Entire Day**.

The screenshot shows a 'Costing Setup' dialog box with the following fields and controls:

- Day Rate:**
 - Active Period: None
 - Period Start: [Slider]
 - Period Length: [Slider]
 - Cost per kWh (\$): 0.00000
- Night Rate:**
 - Active Period: Entire Day
 - Cost per kWh (\$): 0.00000
- SP Costing Enabled:**
- Level (%):** [Field]
- Buttons:** OK, Cancel

3. If the Active Period in the Day Rate pane is **None**, move the **Period Length** slider slightly so that **SP PowerPack** displays an actual time period.

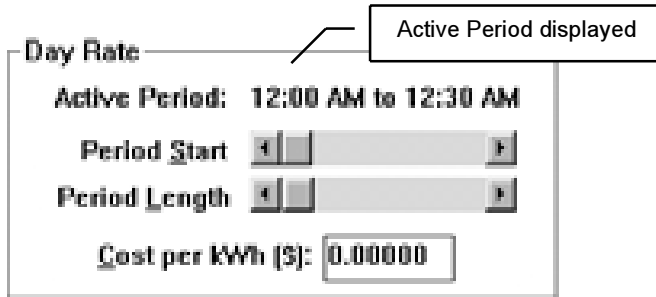

4. To set-up a day rate and a night rate, move the **Period Start** slider to specify the start of the peak billing period. The Active Period in the Night Rate pane adjusts automatically.
5. Move the **Period Length** slider to specify the end of the peak billing period. The Active Period in the Night Rate pane adjusts automatically.

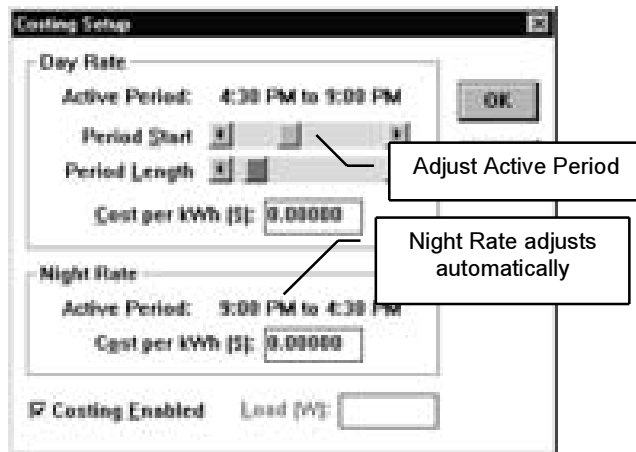

6. To set-up a single billing rate, move the **Period Length** slider to the far right so that the Active Period displays **Entire Day**. The Active Period for the Night rate will display **None**.
7. Double click in the **Cost per kWh** box in the Day Rate pane to highlight the number displayed and then enter the appropriate rate.



NOTE: The units of currency displayed are determined by Windows. To change the units of currency, refer to the International Settings information in your Windows documentation or on-line Help.

8. To add an off-peak rate, adjust the **sliders** to specify two separate billing periods. Then double click in the **Cost per kWh** box in the Night Rate pane and enter the appropriate cost.
9. Click **OK** to make the changes and close the Costing Set-up dialog box.

Displaying Costing Information

Costing information displays only on kWh graphs or lists. To view your consumption costs you need to select the kWh display group in the Measurement Scale Selection dialog box.

Pulse Meter Logging

SP Max allows you to log data from almost any kind of pulse meter. You can modify one of **SP PowerPack**'s initialisation files to add details about the sensors you intend to use, the unit of measurement per pulse, and the calculations associated with a variety of pulse metering applications. Once you have set up the specific pulse information in the **SPMax.INI** file, **SP PowerPack** will calculate consumption values based on your input. For instructions on editing **SPMax.INI**, refer to **Appendix D**.

Pulse logging differs from other kinds of logging in that **SP Max** counts and stores all pulses it receives. The Min/Max and Average modes of data storage do not apply. To complete a pulse meter survey, the logger must be connected to line power. If it is running on battery, pulse data will not be stored.

Displaying Pulse Meter Data

You can display Pulse Meter data as either a simple flow or as a consumption rate. To calculate and display a consumption rate, you need to specify the time period to be used in the calculation and select Pulse Rate as the display group.

1. Download the data and save the file.
2. Click **Pulse Rate Period** in the **Set-up** menu to open the Pulse Rate Selection dialog box.



3. Select the period for which you would like the consumption rate calculated and displayed
4. Click **M** Measurement Scale in the **S** Set-up menu to open the Measurement Scale Selection dialog box.



5. To display the measured pulses as a line graph, select **P** Pulse.
To display a consumption rate as a bar graph, select **P** Pulse Rate.

Logger Status

C **Checking Logger Status**

SP PowerPack allows you to check the status of the logger. The Logger Status dialog box displays the type of logger in use, the logging parameters selected, and the present readings for each enabled channel.

1. Make sure that the logger is connected to the PC.
2. Click **R** Read Status in the **L** Logger menu. **SP PowerPack** communicates with the logger and displays the Logger Status dialog box.

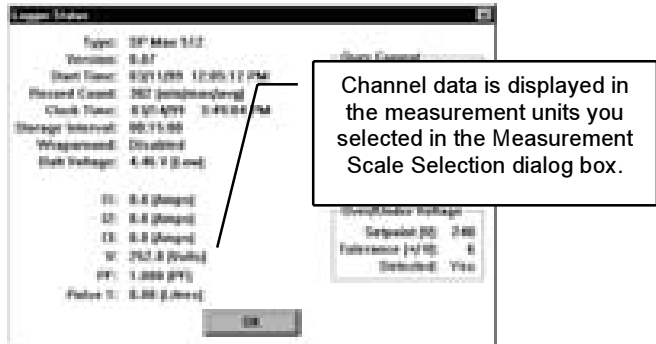

3. Click **OK** to close the Logger Status dialog box.

Resetting the Logger

Resetting the Logger erases the unit's memory and begins a new survey, so be sure to download any data before resetting the unit. You should reset after transporting the logger to the survey site and connecting it to the circuit or equipment you are monitoring.

1. To reset the logger in the field, press the recessed **RESET** button on the unit's front panel.

Should the RESET button fail or if you wish to clear the logger's memory and restart a survey while the unit is connected to your PC, you may reset **SP Max** using **SP PowerPack** software.

1. Click **Reset** in the **Logger** menu. **SP PowerPack** communicates with the logger and then displays a warning message.
2. Click **OK** to clear the logger's memory and begin a new survey.

Adjusting the Logger - PC Communication Speed

SP PowerPack allows you to adjust the speed at which your computer communicates with the logger. If you have a Pentium PC, you can select a communication speed of 19200 baud. However, if you are using a slower computer, you may find you receive incomplete downloads at 19200 baud due to data transmission errors. In this case you can select a slower rate of 9600 baud.

In addition, the software includes a handshaking control feature. When this feature is enabled, your computer can signal the logger to briefly suspend the download. When the computer has caught up, it can then signal the logger to resume data transmission. Handshaking control should normally be enabled.

1. Click **Logger Serial Port** in the **Set-up** menu to open the Logger Port Set-up dialog box.
2. Select a communication speed click in the **MBL Options** pane.



3. To enable handshaking control, select **XON/XOFF** in the **MBL Options** pane.
4. Click **OK** to adjust the communication speed and close the Logger Port Set-up dialog box.

When Things Go Wrong

If you have difficulty with your **SP Max** logger or **SP PowerPack** software, consult the following list of solutions. If you still have trouble, please call us at Elcomponent Ltd or email us at: sales@elcomponet.co.uk.

Menus and Dialog Boxes

There are menu and dialog box items in SP PowerPack that are always dim and unavailable.

Elcomponent Ltd. offers a broad range of logging and metering equipment, all supported by **SP PowerPack**. Some selections in the software relate to features not supported by the **SP Max** logger.

Please contact us for details of other SP Loggers.

Download Problems

The **SP Max** will not download.

- Check the download cable and make sure it is plugged into the correct communications port on your computer.
- Make sure you have selected the correct COM port in the Set-up section of the software. Refer to **Setting Up Silent Partner PowerPack Software** for instructions.
- If you are downloading at 19200 baud, try setting the communication speed down to 9600 baud. Refer to **Adjusting the Logger - PC Communication Speed** for instructions.
- Toggle the XON/XOFF handshaking control.
- If you are using a laptop computer, problems may be encountered due to the very low voltage swing on some portable PC serial ports. Check download performance on a desktop PC to verify if this is an issue.

When accessing Silent Partner Series loggers, the SP POWER Software sends a query to the logger which in turn generates a specific acknowledgement from the logger. An error message is generated if this specific acknowledgement is not received. Possible causes for this include:

- The selected comm port is allocated to a modem. Verify by running Terminal or Hyperterminal. Any response from the port to an 'AT' command (with the logger disconnected) indicates a problem.
- If the first test does not indicate a problem, the possibility remains that another peripheral (most often a network card) is using the same IRQ

as the comm port. Other devices may function correctly because they rely on means other than the IRQ for data validation. SP POWER uses Windows API function calls and will not work if an IRQ conflict exists on the port.

- A similar situation exists if the port is sharing the same hardware address as another device.
- Older PCs using early version UART chips (notably 8250 or 8251) may not have sufficient resources to receive high speed data properly if X On/X Off is disabled. The same problems can be generated if processor speed is set too slow.
- Some PCs, especially those running windows 3.1 may have third party comms drivers installed. These may cause problems with software designed to run with standard Windows drivers.
- In addition to the above it is possible that shortage of RAM will cause an invalid logger response although this is highly unlikely if other programs are functioning correctly.
- If problems are experienced with running SP PowerPack Software it is recommended that a test be made on a stand-alone PC running Windows 95/98 if possible, as a control reference prior to troubleshooting as detailed above. Because W95/98 is more sophisticated in the way it deals with both hardware and software installations, conflicts are less likely than in earlier versions.

The software reports an “Invalid Wakeup Response”, or “Scan Ports for Logger” says that no logger was found.

- Make sure the download cable is plugged in before pressing the scan button.
- If you have unplugged a serial mouse and then plugged the logger into that port, it probably will not work. The reason for this is that the Windows mouse driver will report that the port is still in use by the mouse, regardless of whether or not it is physically connected. If this happens, Windows will not allow **SP** to use that port for communications. This can be overcome by using a different port for communication with the logger. Refer to **Setting Up SP PowerPack Software** for instructions.
- Ensure that the port you are using actually works. You can do this by attempting to communicate with some other device such as an external modem.

Time and Date

The time and date on all of the graphs and printouts is wrong.

- Make sure you have set the logger's clock using the Set Time and Date function in the software. Refer to **Synchronising Logger Time and Date with the PC** for instructions.
- Ensure that your computer's time and date are set correctly.
- Make sure that you press the RESET button on the logger to begin each survey.

All of the times on the graphs and reports are in 24-hour format, but I want 12-hour format (or the reverse).

The dates appear in the wrong format.

The way in which times and dates are displayed in the **SP** software is determined by the International Settings portion of Control Panel in Windows. For information on changing the International Settings, refer to your Windows documentation on on-line Help.

Printing

I click on the Cancel button when printing, but the printer keeps on going.

Printing can continue after you click the Cancel button for several reasons. Windows has a feature called Print Manager which acts as a background print spooler. The function of a print spooler is to allow printing in the background, freeing up your computer for more important things. If Print Manager is enabled, **SP PowerPack** prints to Print Manager instead of to the printer. Print Manager, in turn, sends the data to the printer leaving the computer free for other tasks. Pressing Cancel stops data from going to Print Manager, but it will not stop Print Manager from sending the data it already received to the printer.

To remedy this situation, cancel the print job from Print Manager.

- Select the proper print job from the list and delete it.
- You may wish to disable Print Manager and print directly to the printer. For information on disabling Print Manager, refer to your Windows documentation or on-line Help.

Your printer may also continue to print if it has a large amount of on-board memory. This memory serves the same purpose as Printer Manager by providing a temporary storage space for the data to be printed so that the computer can move on to more important tasks.

- If Print Manager is disabled and your printer continues to print after you click Cancel, reset your printer. This should clear any data stored in the printer's memory. If your printer does not have a reset switch, turn the printer off and then on again.

Display

The colours on the Graph are difficult to see on the screen.

Refer to **Appendix A** for information on changing **SP PowerPack**'s graph colours.

Appendix A - SILPRTNR.INI File Settings

SP PowerPack stores some of its configuration information in a special file called SILPRTNR.INI. You can edit this file using Notepad or any other text editor.



NOTE: This file should only be modified by advanced users.

Customising Graph Colours

If the colours used in the measurement graph are not to your liking, you can change them by editing items in the “[GraphPref]” section of the SILPRTNR.INI file shown below.

```
[ GraphPref]

Meas1RGB=255,0,0      ;Channel 1 (I1) Avg
Meas2RGB=0,255,0     ;Channel 2 (I2) Avg
Meas3RGB=0,0,255     ;Channel 3 (I3) Avg
Meas20RGB=128,0,0    ;Channel 4 (V) Avg
Meas21RGB=0,128,0    ;Channel 5 (PF) Avg
Meas22RGB=0,0,128    ;Channel 6 (Pulse)
Meas4RGB=255,0,0     ;Channel 1 Min
Meas5RGB=255,0,0     ;Channel 1 Max
Meas6RGB=0,255,0     ;Channel 2 Min
Meas7RGB=0,255,0     ;Channel 2 Max
Meas8RGB=0,0,255     ;Channel 3 Min
Meas9RGB=0,0,255     ;Channel 3 Max
Meas10RGB=128,0,0    ;Channel 4 Min
Meas11RGB=128,0,0    ;Channel 4 Max
Meas12RGB=0,128,0    ;Channel 5 Min
Meas13RGB=0,128,0    ;Channel 5 Max
TotalRGB=128,0,128   ;Calculated Total (kWh)
GridRGB=127,127,127 ;Graph Grid
```

The items that control the colours are named from Meas1RGB= to Meas22RGB=, TotalRGB= and GridRGB= as shown below. The three numbers separated by commas after each of these names determine the colour for that item by specifying the amount of Red, Green and Blue ‘pigments’ used, with the value of each pigment ranging between 0 and 255. Some sample colours are listed below. You can also experiment with the colour palette in the Windows Paint program to determine the RGB values for other colours:

Colour	Red	Green	Blue
Black	0	0	0
Blue	0	0	128
Green	0	128	0
Cyan	0	128	128
Red	128	0	0
Magenta	128	0	128
Brown	128	128	0
Light Grey	128	128	128
Dark Grey	192	192	192
Light Blue	0	0	255
Light Green	0	255	0
Light Cyan	0	255	255
Light Red	255	0	0
Light Magenta	255	0	255
Yellow	255	255	0

If you will be printing graphs on a black and white printer, be aware when choosing alternative colours that shades for which the sum of the Red, Green and Blue values is less than 382 will be printed as black, whereas colours for which the sum is greater than 381 will be printed as white.

Other SILPRTNR.INI Items

The remaining items in the **SILPRTNR.INI** file reflect various options that are selected while using the software and are changed while running **SP Power Pack**.

Appendix B - SPPOWER.INI File Settings

 **NOTE: The following section is intended for advanced users.**

Customising SP Power Calculations

Editing the **SPPOWER.INI** file allows you to set some of the computational parameters for the Power feature of the software. **SP PowerPack** refers to **SPPOWER.INI** for the options it displays in the Ratio/Power dialog box's drop-down lists. You can edit these entries to add custom line voltages, fixed power factors, etc.

If you open **SPPOWER.INI** in Windows Notepad or a similar text editor, the file will resemble the sample shown on the following page.

 **NOTE: Changes to the SP POWER.INI file should be undertaken with caution, since incorrect entries could cause erroneous calculations.**

```
;SP Power Value File
[ Defaults]
V1Phase=110, 120, 220, 240, 347
V3Phase= 208, 380, 415, 600
HVRatio=11kV:110, 11kV:240, 1000:110
LoadType=Office 0.9, Factory 0.85, Refrigeration 0.8,
Heating 1.00, Lighting 1.00, Motor 0.80
ExtCT=100:5, 200:5, 300:5
kWhPeriod=15

V1Phase=      Lists the voltages that appear in the Voltage
Range box for single phase supply types.
V3Phase=      Lists the voltages that appear in the Voltage
Range box for three phase supply types.
HVRatio=      Lists the PT ratios that appear in the PT Ratio
box. Each entry is in the format <primary
voltage>:<secondary voltage>. A comma separates individual
entries.
LoadType=     Lists the pre-defined Power Factor values that
appear in the Load Type (PF) box. Each entry is in the
format of <description> <space> <Power Factor value>
ExtCT= Lists the CT ratios that appear in the External CT
box. Each entry is in the format <primary
voltage>:<secondary voltage>. A comma separates individual
entries.
kWhPeriod=    Defines the calculation period in minutes used
when computing kWh. This value is set to 15 in North
America, 30 for Europe.
```



NOTE: You must enable Average recording in the Logger Set-up section in order to calculate power. If you record only Min/Max information, you will not be able to access the Ratio/Power Selection dialog box.

Over/Under Current Detection in the Logger

An undercurrent condition is detected in the logger when:

I1 channel current < configured Undercurrent Limit.

An overcurrent condition is detected in the logger when:

I1, or I2, or I3 current > configured Overcurrent Limit.

Over/Under Voltage Detection in the Logger

An undervoltage condition is detected in the logger when:

Line Voltage < configured Setpoint Voltage - Tolerance.

An overvoltage condition is detected in the logger when:

Line Voltage > configured Setpoint Voltage + Tolerance

Average Calculations

When you enable the Average data storage mode, the value **SP PowerPack** stores is calculated based on the following numbers of samples per storage interval.

Storage Interval	Samples/Average	Storage Interval	Samples/Average
1 second	4	2 minutes	480
2 seconds	8	3 minutes	720
3 seconds	12	4 minutes	960
4 seconds	16	5 minutes	1200
5 seconds	20	6 minutes	1440
6 seconds	24	7 minutes	1680
7 seconds	28	8 minutes	1920
8 seconds	32	9 minutes	2160
9 seconds	36	10 minutes	2400
10 seconds	40	11 minutes	2640
20 seconds	80	12 minutes	2880
30 seconds	120	13 minutes	3120
40 seconds	160	14 minutes	3360
50 seconds	200	15 minutes	3600
1 minute	240		

Current and Voltage Combinations for Calculating Power

SP PowerPack is very intelligent and can generally determine the appropriate metering systems depending on the way in which the logger has been configured. The chart below explains how to configure your logger depending on the voltage distribution system you wish to monitor.

Supply Type	Required Logger Configuration
1P2W	1 Current <u>or</u> Voltage, Current I1 and Power Factor
1P3W	2 Currents <u>or</u> Voltage, Current I1, Power Factor plus Current I2 or I3
3P3W	1 Current <u>or</u> 3 Currents <u>or</u> Voltage, Power Factor and <u>either</u> Current I1 or 3 Currents
3P4W	1 Current <u>or</u> 3 Currents <u>or</u> Voltage, Power Factor and <u>either</u> Current I1 or 3 Currents

Note that the logger measures Power Factor by determining the phase angle between the Voltage and the Current 1 (I1) channel input signals. If the Voltage and I1 Current channels are not both logged a fixed Power Factor can be selected for use in the power calculations instead of that measured by the logger.

SP PowerPack Power Calculations

SP PowerPack calculates power values for each channel as shown below:

Supply Type	Channel Power
1P2W 1P3W 3P4W	$V_{\text{PHASE-NEUTRAL}} \times I \times \text{PF}$
3P3W	$\frac{V_{\text{PHASE-PHASE}} \times I \times \text{PF}}{\sqrt{3}}$

In all cases, Total Power is the sum of the power for all phases. The total for a multiple supply type for which only 1 Current is measured is calculated assuming a balanced load and is the power in the measured circuit multiplied by the number of phases of the supply.

Appendix D - SPMax.INI File Settings (CT Ratios and Pulse Channel Configurations)

 **NOTE:** The following section is intended for advanced users.

SP PowerPack allows you to specify the CT and PT ratios and the pulse meter types which are available within the software for logger configuration. You do this by editing the **SPMax.INI** file. If you open **SPMax.INI** in Windows Notepad or a similar text editor, the file will resemble the sample shown below.

```
;SPMax.ini file

[Current] ;CT Ratios for I1-I3 Channels
Ratio= 5, 10, 20, 50, 100

[Voltage] ;PT Ratios for Line Input Voltage Channel
Ratio= 240

[Pulse] ;Meter types and units
;Type Number, Name, Pulses per unit, Unit of measure,
Unit abbreviation, Rate Type
Type01=Water, 1000, Litres,l
Type02=PCount, 1, Counts, c
Type03=W Demand, 0.001, W, W, HourRate
```

[Current] Group

In the “Ratio=” item, list the current clamp types that you would like to appear in the Configuration/Range CT list. Multiple items in the list are separated by a comma.

[Voltage] Group

In the “Ratio=” item, list the line voltages that you would like to appear in the Configuration/Range PT list. Multiple items in the list are separated by a comma.

[Pulse] Group

Each item in this group is used to define the characteristics of a pulse meter type which is available for selection from the Configuration/Sensor

list. The meter descriptions are identified by a type number followed by a list of up to 5 parameters in the order shown below:

Type Number

The meter type number at the start of the line is in the form "Typexx=", where xx can range from 01 to 99 to allow up to 99 pulse meter types. The type number for the selected pulse meter is stored within the logger during configuration updating and is saved along with the survey data after a download. When survey data or the logger status is displayed, the configured type number is used to select the characteristics of the pulse meter from this file.

Name

This parameter contains the name of the meter which appears in the Configuration/Sensor list. The name can be up to 10 letters long.

Pulses Per Unit

This parameter specifies the number of pulses from the meter which represent 1 of the measured units and can be up to 6 digits long (including the decimal point). Data displayed for the Pulse display group selection are scaled by this number as:

$$\text{Pulse Value} = \frac{\text{Pulse Count From Logger}}{\text{Pulses Per Unit for configured meter type}}$$

For example, the Type01 meter shown in the sample file outputs a pulse for every millilitre of liquid measured, so a unit quantity of 1 litre would be indicated by 1000 pulses. Conversely, the Type03 W Demand meter outputs kW pulses, so each Watt unit is only 1/1000 of a pulse, or 0.001.

Unit of measure

This parameter specifies the name of the measured units to be used for identification with the survey data. The name can be up to 6 letters long.

Unit abbreviation

This parameter identifies the abbreviation to be used to identify the pulse meter data type when displaying the data and can be up to 3 letters long.

Rate x Time Calculation

This option is set to y (yes) or n (no) and sets the 'pulse rate' option. If it is set to y, pulse rate data will be available, calculated as:

$$\frac{\text{Pulse Count}}{\text{Sample Interval}} \quad \times \quad 30 \text{ minutes}$$

Examples:

Type 01 = Water, 1000, Litres, L, n

means that option 1 in the list of available meters will be:

A **water** meter, with a pulse rate of **1000** pulses per **litre**, where the abbreviation **L** is used for the unit of measure, and there is **no** calculation of rate x time.

Type 02 = Gas, 0.1, cu.m, m3, y

means that option 2 will be:

A **gas** meter, with a pulse rate of 0.1 pulses per **cubic metre** (10 cubic metres per pulse) where the abbreviation **m3** is used for the unit of measure, and the rate x time calculation is enabled (**yes**).

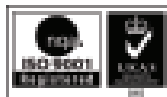

Unit 5 Southmill Trading Centre
Southmill Road
Bishop's Stortford
Herts CM23 3DY 07/06

T: 01279 503173
F: 01279 654441
E: sales@elcomponent.co.uk
W: www.elcomponent.co.uk